

PYD 1598 / 7655



Low Power Dual Element Large Field-of-View Pyro

The PYD 1598 is a serial opposed format, two elements detector based on pyroceramic. The signal is converted to a digital value using Sigma-Delta and DSP techniques. A configurable motion detection unit is implemented. Once motion was detected, an interrupt will be send to the host system. Putting the host system to sleep an overall ultra low power consumption will be achieved. All data is accessible by the host system to enable advanced signal analysis with your own detection criteria. Excelitas digital solutions provide excellent EMI immunity.



Product Specification

Features

- Integrated digitization
- Motion detection unit with Interrupt function
- Low-power consumption of only 3 μ A at 1.8V.
- High responsivity ceramic pyroelectric elements
- Dual detector with $2 \times 1 \text{ mm}^2$ elements
- 130° field-of-view
- TO-5 metal housing for high EMI immunity
- Optimal for fast designs

Applications

- Long distance motion detection (with lens)
- Energy saving applications
- Intrusion alarms
- Horizontal mounting applications
- Battery operation
- Gesture direction recognition
- Touchless switch

Contents

1 Physical Characteristics	3
1.1 Pyro-Electric Elements	5
1.2 Optical Properties	6
1.3 Filter Properties	7
2 Electrical Characteristics	8
2.1 Absolute Maximum Ratings	8
2.2 Electrical Data	9
2.3 Interface Overview	10
2.4 Motion Detection Unit	11
2.5 Configuration Register	11
2.6 Serial In Interface	13
2.7 Direct Link Interface	13
3 Handling, Operation and Precautions	16
3.1 Handling	16
3.2 Operation	16
4 Quality and Statements	17
5 Packaging	18

1 Physical Characteristics

Table 1: Summary of physical characteristics. Parameters and data refer to an ambient temperature of $25 \pm 3 \text{ }^\circ\text{C}$.

Parameter	Symbol	Min	Typ	Max	Unit	Remarks/Conditions
Housing			TO-5			see fig. 1
Lead Length			13.2		mm	see fig. 1
Field of View	FOV		130		$^\circ$	see sec. 1.2
Element Size			2×1		mm	see fig. 1
Spacing			1		mm	see fig. 1
Optical Distance			600		μm	see fig. 1
Responsivity	R	3.3	4.0		kV W^{-1}	see sec. 1.1
Match	$(R_A - R_B)/R_A$			10	%	see sec. 1.1
Noise			20	78	μV_{pp}	see sec. 1.1
IR-Filter			Standard			see sec. 1.3

Figure 1: Dimensions and Connections. Explanations follow in this document.

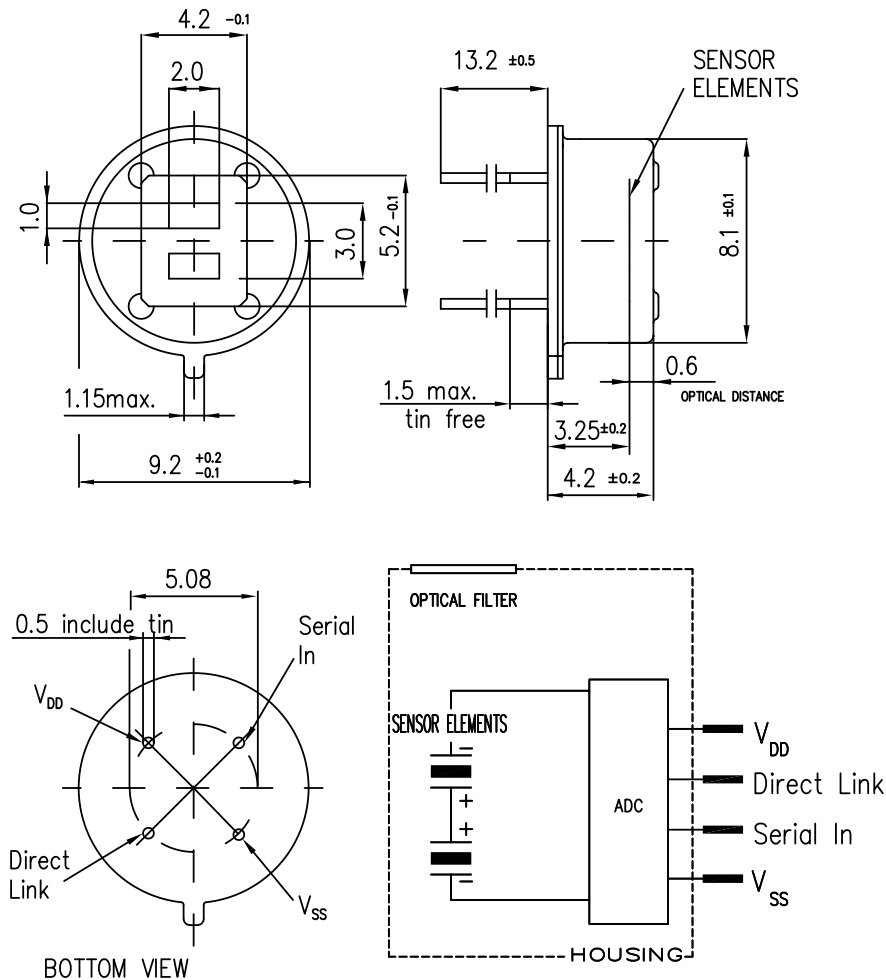

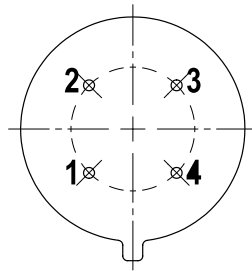

BOTTOM VIEW

Pin Number	Symbol	Description
1	Direct Link	1-wire digital interface for data readout. An external decoupling capacitor close to the pin is recommended. See technical note for details.
2	VDD	Positive power supply. An external decoupling capacitor close to the pin is recommended. See technical note for details.
3	Serial In	1-wire digital interface for detector configuration. An external decoupling capacitor close to the pin is recommended. See technical note for details.
4	VSS	Negative Power Supply. Should be set to the host ground.

1.1 Pyro-Electric Elements

The element configuration is shown in figure 1. It features a dual element configuration in a serial opposed format. Its typical application is long distance, wall mounted, motion detection .

Figure 2: Test set up for the measurement of responsivity and match.

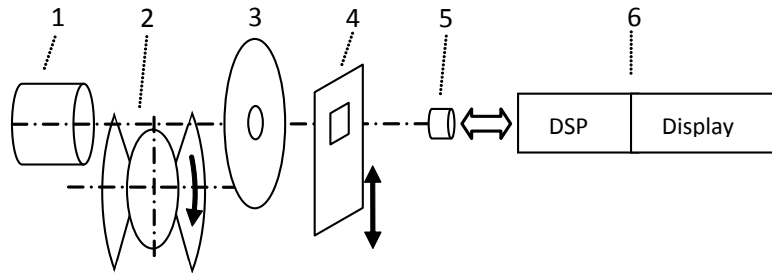
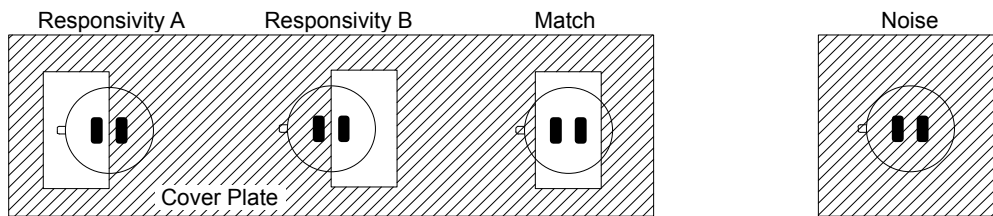

Figure 3: Masking of elements to test the electrical parameters.



The typical set-up for the measurement of responsivity and match is illustrated in figure 2. The black body (BB) radiator (1) is set to 373 K (100 °C). The signal is modulated by a rotating chopper (2). An aperture (3) is used to adjust the radiation flux. The cover plate (4) is masking the elements as shown in figure 3. The sensor (5) is interfaced to a signal processing chain (6). To measure noise, a bandpass filter in the range of 0.4 Hz to 10 Hz is applied.

Responsivity (*R*) and match are measured at a modulation frequency of 1 Hz.

The match is defined by

$$\frac{\text{Match}}{R} \times 100 \tag{1}$$

Noise is measured shut from infra-red energy. The measurement is performed after a settling time of 10 min at an ambient temperature of 25 °C ± 3 °C. Noise is monitored for the duration of 600 s .

1.2 Optical Properties

Figure 4: Illustration for the definition of the horizontal field of view (FOV).

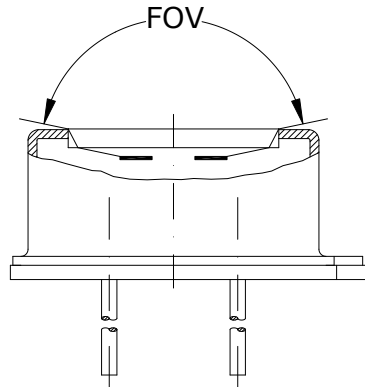

The horizontal field of view (FOV) as drawn to figure 4 is given as the geometrically unobstructed light path to both elements. The FOV of 130° is given for the optical light acceptance with the full so-called common mode suppression.

The optical distance as it is given in figure 1 represents the effective focal plane for the application specific optics. The optical distance is shorter than the geometrical due to refraction of light in the filter.

1.3 Filter Properties

Table 3: Filter properties

Parameter	Symbol	Min	Typ	Max	Unit	Remarks/Conditions
Average Filter Transmittance	T_A	77			%	$7.5 \mu\text{m} < \lambda < 13.5 \mu\text{m}$
Average Filter Transmittance	T_A			0.5	%	$\lambda < 5 \mu\text{m}$
Cut-on Wavelength	$\lambda(5\%)$	5.2	5.5	5.8	μm	at 25°C

Figure 5: Filter transmittance, typical curve

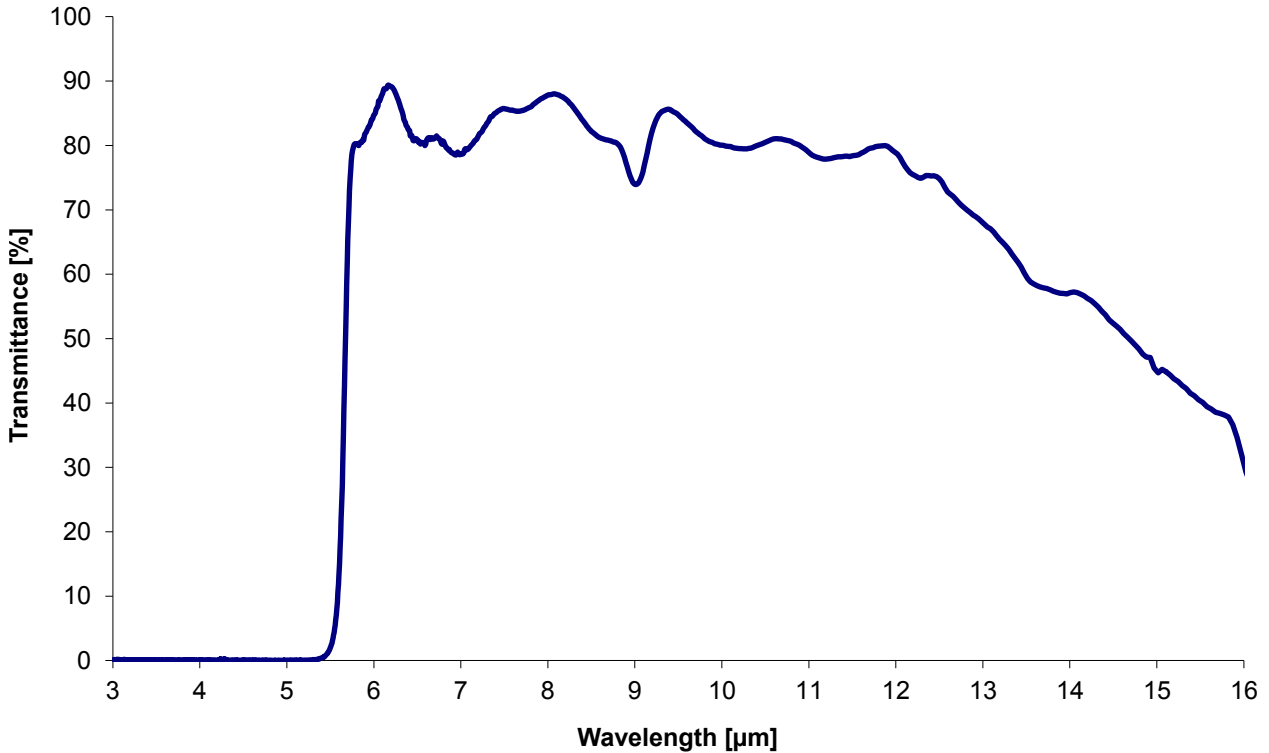

2 Electrical Characteristics

2.1 Absolute Maximum Ratings

Table 4: Absolute Maximum Ratings. Data applicable to operation at free-air temperature range.

Parameter	Symbol	Min	Typ	Max	Unit	Remarks/Conditions
Voltage at any pin	$V_{DD}, V_{Serial In}, V_{Direct Link}$	-0.3		3.6	V	
Current into any pin	I_{pin}	-100		100	mA	
Storage Temperature		-40		85	°C	< 60 % r.H.
Operating Temperature		-40		70	°C	

Stresses beyond the limits listed in table 4 may cause permanent damage to the device. Exposure to absolute maximum ratings for long time may affect the device reliability and may lead to deterioration of any parameter.

2.2 Electrical Data

Table 5: Electrical Data. Unless specified differently all data refers to $25 \pm 3^\circ\text{C}$.

Parameter	Symbol	Min	Typ	Max	Unit	Remarks/Conditions
Operating Voltage	V_{DD}	1.8	3	3.6	V	
Supply Current	I_{DD}		3	3.5	μA	$V_{DD} = 1.8\text{V}$, no load
SERIN						
Input Low Voltage	V_{SIL}	-0.3		$0.2V_{DD}$	V	
Input High Voltage	V_{SIH}	$0.8V_{DD}$		$V_{DD} + 0.3$	V	Max $V < 3.6\text{V}$
Input Current	I_{SI}	-1		1	μA	$V_{SS} < V_{IN} < V_{DD}$
Data Clock Low Time	t_{SL}	200		2000	ns	
Data Clock High Time	t_{SH}	200		2000	ns	
Data In Hold Time	t_{SHD}	80		150	μs	
Data Load Time	t_{SLT}	650			μs	
Direct Link						
Input Low Voltage	V_{DIL}	-0.3		$0.2V_{DD}$	V	
Input High Voltage	V_{DIH}	$0.8V_{DD}$		$V_{DD} + 0.3$	V	Max $V < 3.6\text{V}$
Input Current ²	I_{DI}	-1		1	μA	
Data Set-up Time	t_{DS}	120		150	μs	
Data Clock Low Time	t_{DL}	200		2000	ns	
Data Clock High Time	t_{DH}	200		2000	ns	
Data Bit Settling Time	t_{BS}			2	μs	$C_{LOAD} < 10\text{pF}$
Sample Time	t_{SMPL}	2.0		12.5^1	ms	
Bit Time	t_{BIT}			22	μs	
Update Time	t_{UP}	1250			μs	
ADC Resolution³						
PIR ADC Sensitivity			6.5		$\mu\text{V}/\text{Count}$	
PIR ADC Offset		7000	8000	9000	Counts	in stable condition
Sensitivity of T_{AMB}						
Counts at 300 K (27 °C)		6620	8200	9980	Counts	14 bits ADC resolution
LPF cut-off frequency	f_1		7		Hz	
HPF cut-off frequency	f_2		0.2/0.4		Hz	configurable
Internal Clock Frequency	f_{CLK}	28	32	40	kHz	

¹ Maximum limits only applicable in "Interrupt Read Out Mode".

² Pull Up/Down resistors at Direct Link are not applicable.

³ Effective ADC range is from 511 counts to $2^{14} - 511$ counts .

2.3 Interface Overview

The following sections provide a coarse overview and specify the interface properties. For a deeper discussion of implementation and application related topics, refer to the corresponding application note of this sensor family.

Figure 6: Block Diagram

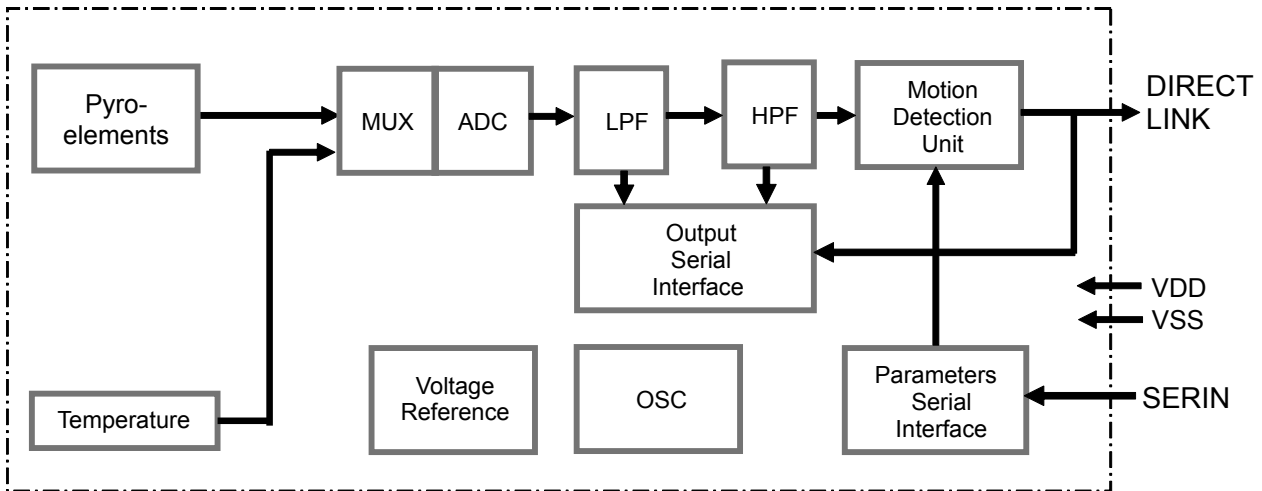

The pyro-electric sensing elements are connected to a built-in IC, whose functions are shown in the block diagram 6. The low power DigiPyro™ contains pyro-electric elements sensitive to IR radiation and an ASIC for the digital signal processing within the sensor package. The ASIC includes an on-chip oscillator, a voltage reference, an analogue-to-digital (ADC) converter with multiplexed inputs (MUX) for the pyro-electric elements as well as for the internal temperature sensor.

Included are also Low- and High-Pass Filters and a Motion Detection Unit. The serial interface "SERIN" is provided to configure the internal registers. The configuration memory is volatile which means that after power up the register settings are undefined.

A second serial interface called "DIRECT LINK" can be configured to:

1. Send an interrupt once a motion event is detected.
2. Read a continuous data stream from the detector.

2.4 Motion Detection Unit

Figure 7: Example for the detection of motion after BPF.

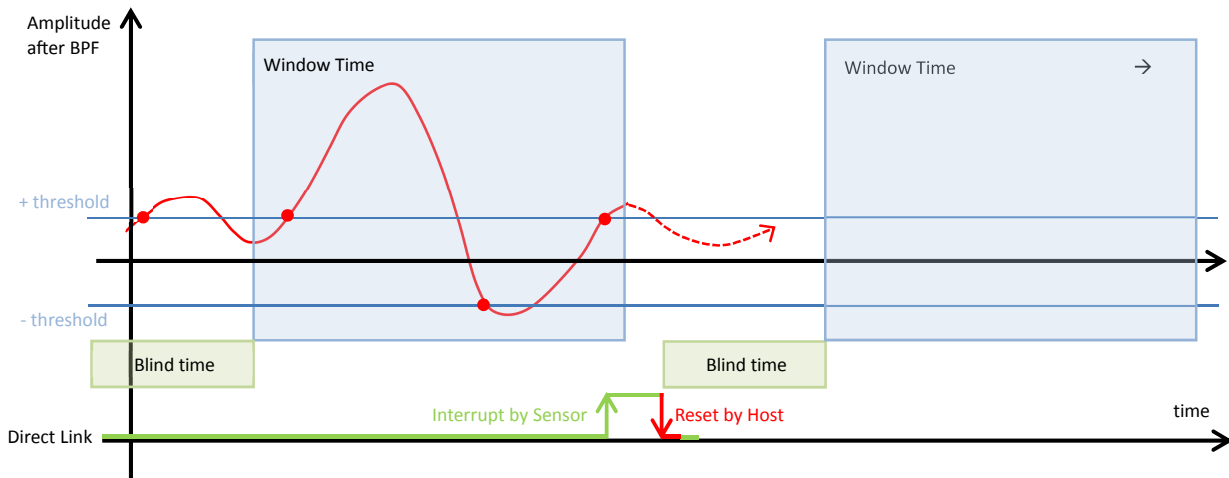

Figure 7 illustrates the processing of the pyroelectric sensor signal. The signal is always analysed after band pass filtering (BPF).

To enable the internal Motion Detection Unit configure the sensor to "Wake Up" mode (see section 2.5). The DIRECT LINK will be pulled HIGH when the motion criteria are met. DIRECT LINK will not automatically fall back to LOW. To clear the interrupt, DIRECT LINK needs to be pulled to LOW by the micro-controller for at least 160 µs. When the alarm event is cleared by resetting the interrupt, any further motion detection is stopped for the programmed blind time.

For details please refer to the corresponding technical note.

2.5 Configuration Register

Table 6: Configuration Register Content. Register Contents are undefined after Power-Up.

Bit#	Description	Size[bit]	Remarks
[24:17]	Threshold	8	Detection threshold on BPF value
[16:13]	Blind Time	4	$= 0.5 s + [\text{Reg Val}] \cdot 0.5 s$
[12:11]	Pulse Counter	2	$= 1 + [\text{Reg Val}]$
[10:9]	Window Time	2	$= 2 s + [\text{Reg Val}] \cdot 2 s$
[8:7]	Operation Modes	2	0: Forced Readout 1: Interrupt Readout 2: Wake Up 3: Reserved
[6:5]	Signal Source	2	0: PIR (BPF) 1: PIR (LPF) 2: Reserved 3: Temperature Sensor
[4:3]	Reserved	2	Reserved: Must be set to dec 2
[2]	HPF Cut-Off	1	0: 0.4 Hz 1: 0.2 Hz
[1]	Reserved	1	Reserved: Must be set to dec 0
[0]	Count Mode	1	count with (0) or without (1) BPF sign change

Threshold The pyroelectric signal must exceed that threshold after band-pass filtering in order to be recognized by the pulse counter. The threshold applies to positive as well as negative pulses by the pyroelectric element. The threshold must be configured to a value which meets the application's requirements.

Blind Time The purpose of blind time is to avoid immediate re-triggering after a motion event was detected and an interrupt was signaled. The blind time starts counting after pulling the "DIRECT LINK" line from high to low by the host system. The time can be selected between 0.5 s and 8 s in steps of 0.5 s.

Pulse Counter The amount of pulses above the threshold is counted in a specified window time. It triggers the alarm event (DIRECT LINK is pushed by the ASIC from low to high) in wake up operation mode. It can be configured from 1 up to 4 pulses. The amount of pulses is application specific.

Window Time The pulse counter is evaluated for pulses above the threshold within a given moving window time. The window time can be set from 2 s up to 8 s in intervals of 2 s. The best setting depends on the application specific motion pattern.

Operation Modes Three operation modes can be selected with this 2 bit wide register value:

- dec 0: "Forced Readout" mode
- dec 1: "Interrupt Readout" mode
- dec 2: "Wake Up" operation mode
- dec 3: Reserved

In "Forced" and "Interrupt Readout" mode the "DIRECT LINK" interface is used to read raw data and configuration settings. The source is defined by the filter source setting. Please refer to section 2.7 for communication details. In wake up operation mode, the internal alarm event unit is used to generate a low to high transition on the "DIRECT LINK" line once the criteria for motion was met. The host system must pull this line from high to low in order to reset the alarm unit.

Signal Source The source of the ADC output can be set to

- dec 0: PIR BPF
- dec 1: PIR LPF
- dec 2: Reserved
- dec 3: Temperature sensor

The signal of the pyroelectric sensor can be observed after low-pass filtering (LPF). The data on the "DIRECT LINK" line will be an unsigned integer in the range of 0 counts..16 383 counts.

After band pass filtering (BPF) the data will be a signed integer in the range of –8192 counts..8191 counts.

If the source is set to the internal temperature sensor, an unsigned integer in the range of 0 counts..16 383 counts will be provided which is proportional to the internal temperature of the sensor. This can be used to ignore false triggers due to difficult conditions such as sudden temperature changes above 1 K min^{-1} .

HPF cut-off The high pass cut-off frequency in the band pass filter can be selected to be

- dec 0: 0.4 Hz
- dec 1: 0.2 Hz

The optimal value depends on the motion pattern and is application specific. Generally speaking the lower cut-off value is used for long distance motion detection.

Count Mode If the mode is set to 0, pulses above the threshold are only counted when the sign of the signal changed after BPF. If set to 1, no zero crossing is required.

2.6 Serial In Interface

Figure 8: Serial Data clocked into Device

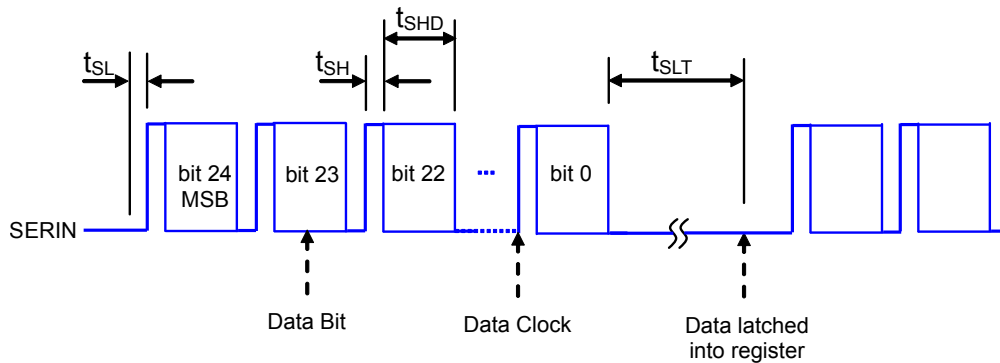

The configuration data is set via the serial input "SERIN" as illustrated in figure 8. During configuration the DIRECT LINK line must be kept LOW by the host system.

The external micro-controller has to generate a LOW to HIGH transition on the SERIN input and subsequently apply the data bit value (LOW or HIGH).

The LOW and HIGH time (t_{SL} and t_{SH}) for the transition can be very short (1 instruction cycle of the micro-controller). The data bit value must be applied for at least $t_{SHD} \geq 80 \mu s$.

Whenever the device has received 25 data bits and the transfer of data bits is interrupted for a period greater than $t_{SLT} > 650 \mu s$, the last data received is latched into the configuration register. The transmission of a 25 bit data word should not be interrupted for more than $150 \mu s$, as the device may latch the data already at this stage. New data is soonest accepted when SERIN has been LOW for at least $t_{SLT} > 650 \mu s$ and the supply voltage is within the specified operating range after Power-Up.

The configuration data is soonest available for read back 2.4 ms after t_{SLT} elapsed. To read back the sensor's configuration, the DIRECT LINK interface is used.

2.7 Direct Link Interface

The DIRECT LINK interface is a bi-directional one wire serial interface which is used to generate an interrupt or to continuously retrieve data from the sensor.

Table 7: Content of the DIRECT LINK data stream when reading sensor out.

Bit#	Description	Size[bit]	Remarks
[39]	Out of Range	1	0: PIR was reset 1: Normal operation
[38:25]	ADC counts	14	Value of selected source
[24:0]	Configuration	25	Register settings

Out of Range The ASIC features an out of range detection. Should the pyroelectric sensor's signal drop below 511 counts or exceed $2^{14} - 511$ counts before band-pass filtering, the input will be shorted for a duration of about 16 ms in order to discharge the sensor. This is indicated by a 0. A normal operation is indicated with a 1. The bit state remains 0 until the first data packet after the shorting operation is read out.

Out of range conditions may occur for example during strong sensor temperature gradients of more than $1 K min^{-1}$.

ADC counts The data represents either ADC counts after low-pass filtering, after band-pass filtering or the reference temperature counts. The band-pass filtered data is represented as a two's complement 14 bit signed

integer value. The low-pass data and the reference temperature data is represented as 14 bit unsigned integer. Band-pass filtered data is updated latest every 20 ms after the last reading. Reading this value out with a faster sampling time may lead to duplicated readings.

Configuration The settings of the alarm event unit is contained here. Details are described in section 2.5.

Figure 9: Data Transmission Diagram

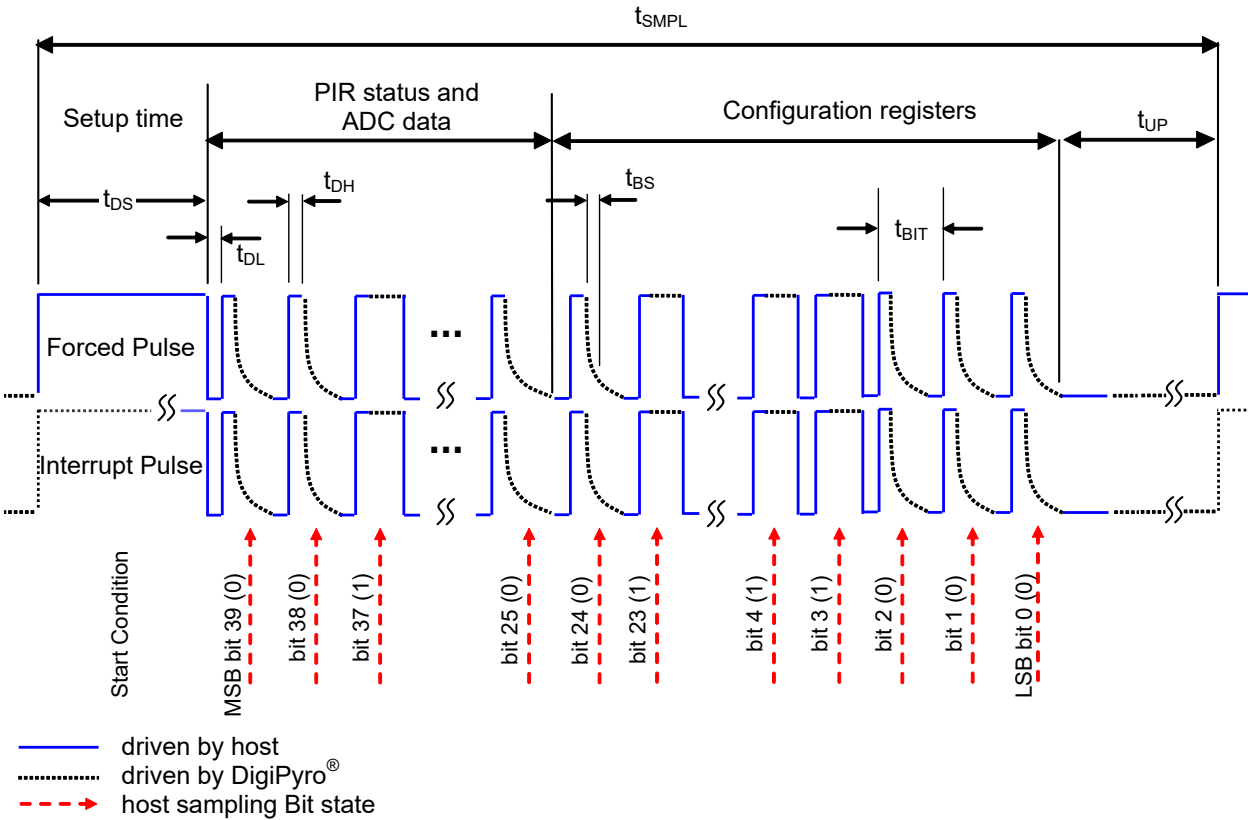

Timing The DIRECT LINK interface communication principle is sketched in figure 9. It can be divided into the start condition and the data stream after it.

The start condition for any communication is indicated by a LOW to HIGH transition of the DIRECT LINK line. That condition can be initiated either by the host system or the sensor. Initiating the condition with the host system is called "Forced Readout" mode. Initiating the condition with the sensor is called "Interrupt (driven) Readout" mode. Whether the sensor or the host is driving the start condition must be set in the sensor's configuration of "Operation Mode" (see sec. 2.5).

Wake up Mode The source for the Interrupt is the sensor's Motion Detection Unit. Once motion was detected (see sec. 2.4) the sensor will pull the line from LOW to HIGH. The DIRECT LINK line will not automatically fall back to LOW. To reset the Motion Detection Unit, the host system must pull the line LOW for at least 160 μ s. The host system can (but does not have to) proceed to the **Readout of Bits** not sooner than 120 μ s after the Interrupt occurred and the DIRECT LINK was HIGH.

In order to recognize the interrupt by the sensor, the host system's connection to the DIRECT LINK line must have a high impedance (high Z) and be set to input.

Forced Readout The sensor is expecting the host system to initiate the communication. Forcing DIRECT LINK to HIGH for at least $t_{DS} = 120 \mu s$ and then pulling it to LOW will start the communication. The host system can resume with the **Readout of Bits**.

Interrupt Readout The sensor will drive the line typically every $t_{SMPL} = 16 \text{ ms}$ HIGH. The host system must then pull the line to LOW in order to start the communication with the sensor. The host system can proceed to the **Readout of Bits** not sooner than $120 \mu s$ after the Interrupt occurred and the DIRECT LINK was HIGH. In order to recognize the interrupt by the sensor, the host system's connection to the DIRECT LINK line must have a high impedance (high Z) and be set to input. The recommended readout mode is the "Forced Readout".

Readout of Bits The readout procedure is started by the forced or interrupt pulse. The low power DigiPyro™ waits for the next LOW to HIGH transition by the host system. The host system pulls the line HIGH and releases it (high impedance Z). The low power DigiPyro™ will pull the line LOW for a 0 bit state or keep it HIGH for a 1 bit state.

The time t_{BS} which the signal needs to settle to a LOW level depends on the capacitive load (e.g. PCB design) at the DIRECT LINK pin. Hence, it is recommended to start implementing the interface with t_{BIT} close to, but shorter than $22 \mu s$ to ensure proper LOW level settling. In next steps reduce t_{BIT} empirically to optimize for reliable data transmission at maximum transmission speed. It is not recommended to choose bit settling times below $2 \mu s$. After reading the line state by the host system, the host pulls the line again LOW to initiate the next bit readout by a LOW to HIGH transition again. The sequence will be repeated until all bits are shifted out. After the last bit of bit[0] the host controller must force DIRECT LINK pin to LOW for at least $t_{UP} > 1250 \mu s$ and subsequently release DIRECT LINK (High Z). This minimum time is required to allow the registers to be updated with latest values before the next read operation.

It has to be considered that t_{BIT} must not exceed $22 \mu s$ to avoid data corruption. Under no circumstances DIRECT LINK may be at LOW level for longer than $22 \mu s$, in case further bits need to be read out. It is recommended that the total time to readout one data packet should not exceed $800 \mu s$ to ensure always latest values. In "Interrupt Mode" the total readout procedure must not exceed $t_{SMPL} < 12.5 \text{ ms}$.

It is allowed to cancel the readout at any position of the data stream. To terminate the readout, DIRECT LINK must be forced to LOW level and kept for at least $t_{UP} > 1250 \mu s$ in order to ensure an update to latest values. In order to reduce settling effects, the data packets have to be read continuously with equal sampling intervals.

3 Handling, Operation and Precautions

3.1 Handling

Shelf Life The product can be stored for 12 months before usage at $-10^{\circ}\text{C}..40^{\circ}\text{C}$ (<60% r.H. at 40°C non condensing).

Storage Avoid storage under high humidity and/or high ambient temperature environments.

ESD The ASIC was designed to withstand a discharge of up to 1.6 kV through a $1.5\text{ k}\Omega$ resistor in series according to the test method MIL-STD-883D / 3015.

Handle the detectors as ESD sensitive devices and protect them from electrostatic discharges. Working areas should be conductive and grounded. When handling detectors, operators shall be grounded.

Mechanical Avoid mechanical stress on the housing and especially on the leads. Be careful when cutting or bending leads to avoid damage. Do not bend leads less than 5 mm from their base. Do not drop detectors on the floor.

Cleanliness Avoid touching the detector window. To clean windows, use only ethyl alcohol with a cotton swab when necessary. Do not expose detectors to aggressive detergents such as Freon, trichloroethylene, etc.

Soldering Conditions For the soldering of the detectors within PCBs, the typically applied and recommended process is wave soldering. The recommended soldering temperature shall not exceed 285°C with a maximum exposure time of 5 seconds. During the automatic wave solder process we strongly advise to restrict preheating when the detector is directly exposed to the radiation of such heaters. In this case, the detector should be protected from the heat.

Manual soldering is also possible when maintaining similar temperature profiles.

Re-flow soldering is not possible due to the high temperature profiles of the process.

Temperatures higher than recommended may affect its performance. Any soldering process should be qualified to avoid damage to the sensor.

3.2 Operation

Humidity The operation below the dew point may affect the performance.

Temperature Strong temperature gradients above 1 K min^{-1} may affect the sensor's performance. Before taking a reading, during testing, and / or operation the unit has to become thermally stable (due to its nature as a thermal detector and the high sensitivity of the device).

All data is specified at room temperature. When operating at other temperatures within the specified operating range, parameters may vary. The detectors might operate outside the quoted range but may have degraded performance.

4 Quality and Statements

Quality Excelitas Technologies is a ISO 9001:2015 certified manufacturer with established SPC and TQM. Detector out-going inspections include the parameters responsivity, match, offset, noise, gross leak. Due to high level mass production, individual data is not stored.

Excelitas Technologies is certified for it's Environmental Management System according to ISO 14001:2015 and for the Occupational Safety and Health Management System according to ISO 45001:2018.

All devices employing PCB assemblies are manufactured according IPC-A-610 class 2 guidelines.

The infra-red detection product line is certified for ANSI/ESD S.20.20:2014.

Package This IR-detector is sealed to pass a He-leakage test with maximum leak rate of 1×10^{-8} mbar l s⁻¹.

Tracability The marking of the detector includes the principal type, a 4 digit number that represents the Excelitas identification number. A 4 digit date code is provided in addition to that. It consists of the production year and week. The marking is printed on the top or side of the detector.

Safety Modern high-tech materials are applied in the production of our pyro-electric detectors. Some of these materials are sensitive to high temperature exposure or to specific forms of stress. Our parts are compliant with environmental regulations such as RoHS 2011/65/EU. For details please contact our local representatives. We recommend to always check your local regulations. Disposal shall only be carried out in accordance with the latest legislation and directives. In Europe, WEEE directives must be followed.

The leads of these detectors have been pre-tinned with lead free tin process and may be applied through lead-free solder processes. As such the detectors will enable the design of RoHS compliant products.

Liability Policy The contents of this document are subject to change. The details of this document are valid by the specified revision date. Excelitas reserves the right to change at any time total or part of the content of this specifications without individual notification. Customers should consult with Excelitas Technologies' representatives to ensure updated specifications before ordering.

Customers considering the use of Excelitas Technologies devices in applications where failure may cause personal injury or property damage, or where extremely high levels of reliability are demanded, are requested to discuss their concerns with Excelitas Technologies representatives before such use.

The Company's responsibility for damages will be limited to the repair or replacement of defective product. As with any semiconductor device, thermopile sensors or modules have a certain inherent rate of failure. To protect against injury, damage or loss from such failures, customers are advised to incorporate appropriate safety design measures into their product.

5 Packaging

The Excelitas Technologies tube packaging system protects the product from mechanical and electrical damage and is designed for manual unloading. Figure 10 shows the basic outline.

The system consists of tubes which are protected against ESD (5). The devices are loaded sequentially and fixed with stoppers (4). Up to 50 parts are filled into one tube. In total up to 20 tubes are placed in one paper box (3) filled with protective sponges (8,9,10).

Information labels, ESD labels and bar-code Labels (7) are placed on the box. The label (7) contains the following Information:

- Producer = Excelitas Technologies
- Origin
- Product Name
- Full BAU (unique identification) number
- Batch Number
- Packaging Date

Figure 10: Information about the packaging of sensors.

