

Thermopile Linear Array Module

TPiL 8T 2246 L3.9 A60 P8 (Part Number: 9638 4327 ; {former 4307})

Revision 5 – Date: 2020/12/01



Product Description

The TPiL 8T 2246 L3.9 A60 P8 consists of a 1x8 element thermopile chip connected to a multiplexer, with analogue and digital circuits for integrated signal processing and interfacing. The sensor module provides an output signal which represents real temperature data for each pixel. It has a lens optic to meet the Field of View (FOV) requirements of the specific application. This module is supplied as ‘A’ version which is calibrated and includes fast internal temperature compensation for ambient error correction.

Functional Diagram

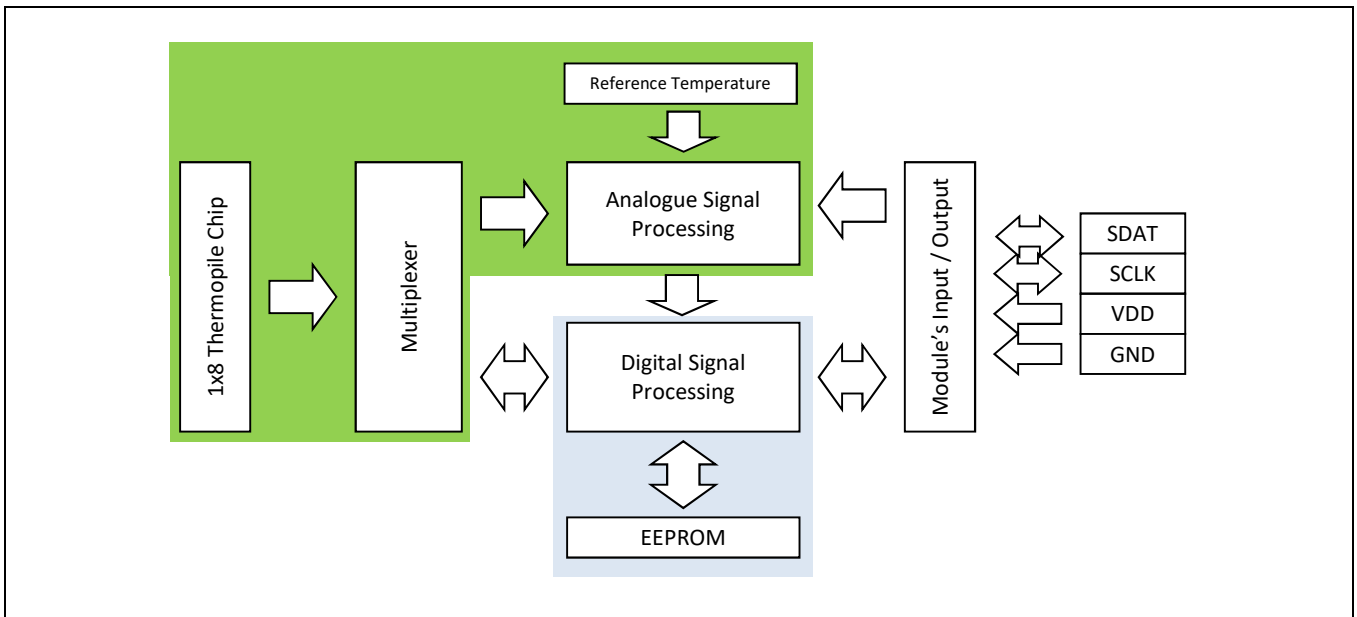

Absolute Maximum Ratings

PARAMETERS	MIN	MAX
Storage Temperature	- 40°C	100°C
Operating Temperature	- 25°C	100°C

Electrical Characteristics

Unless otherwise indicated, all limits are specified for T_{AMB} at 25°C, V_{DD} at 5V.

SYMBOL	PARAMETER	MIN	TYP	MAX	UNIT	CONDITIONS
POWER SUPPLY						
V_{DD}	Supply Voltage	4.5	5.0	5.5	V	-
I_{DD}	Supply Current	-	5.0	6.5	mA	-
SERIAL INTERFACE (SDAT & SCLK)						
V_{iL}	Low level input voltage	-	-	0.8	V	Fall edge
V_{iH}	High level input voltage	$0.8 * V_{DD}$	-	$V_{DD} + 0.3$	V	Rising edge
V_{oL}	Low level output voltage ^{NOTE 1}	-	-	0.4	V	-

NOTE 1: SDAT and SCLK pins have drain output.

Temperature Sensing Range

SYMBOL	PARAMETER	MIN	TYP	MAX	UNIT	CONDITIONS
CALIBRATION SETTINGS						
T_{OBJ}	Calibrated object temperature range	10.0	-	60.0	°C	Emissivity at 99.9%
RESOLUTION T_{OBJ}	Resolution of object temperature	0.5	-	-	°C	-
T_{AMB}	Calibrated ambient temperature range	0.0	-	40.0	°C	-
RESOLUTION T_{AMB}	Resolution of ambient temperature	0.5	-	-	°C	-

AC Characteristics

Unless otherwise indicated, all limits are specified for T_{AMB} at 25°C, V_{DD} at 5V.

SYMBOL	PARAMETER	MIN	TYP	MAX	UNIT	CONDITIONS
t_{start}	Module time to response after power ON	-	-	500	ms	-
$t_{latency}$	Latency time for T_{OBJ}	-	-	180	ms	No filter applied
$t_{pix_refresh}$	Pixel signal refresh time	-	180	230	ms	-
$t_{ptat_refresh}$	PTAT signal refresh time	-	180	230	ms	-
AMPLIFIER						
O_N	Output noise	-	5	-	mV _{pp}	Applicable for V_{pix_i} At default filter setting
SERIAL INTERFACE						
f_{SMB}	Operating frequency	10	-	100	kHz	Please refer to page #6 for specific conditions applicable
EEPROM						
	Data retention time	10	-	-	Years	Max T_{AMB} at 85°C
t_{WR}	Write cycle time	250	-	-	ms	-

Optical Characteristics

Method of FOV Characterisation

Radiation Source
Aperture
IR
Sensor
Rotate sensor to change angle of incidence

Definition of FOV

Relative Output Signal of Sensor
100%
50%
FOV_Y
Angle of Incidence
FOV_Y defined by 50% Relative Output Signal

FOV_X
100%
Angle of Incidence

FOV: Field of View

The sensors' optic defines the Field of View (FOV) of the sensor.

FOV_x is defined as the incident angle difference between peak signal position of Pixel 1 and Pixel 8.

The FOV_y is defined as the incident angle difference, where the sensor relative output signal is at 50% as shown in diagram on the left.

Sensor's Tab
Pixels' Orientation

SYMBOL	PARAMETER	MIN	TYP	MAX	UNIT	CONDITIONS
CAP TYPE TO39 L3.9						
FOV _x	Field of View X Direction		50		°	Please refer to Definition of FOV above
FOV _y	Field of View Y Direction		4		°	
OA	Optical Axis	- 6.5	0	6.5	°	-
LENS TRANSMISSION						
Average Transmission		-	52	-	%	Wavelength from 5.5µm to 13.5µm

Connection Information

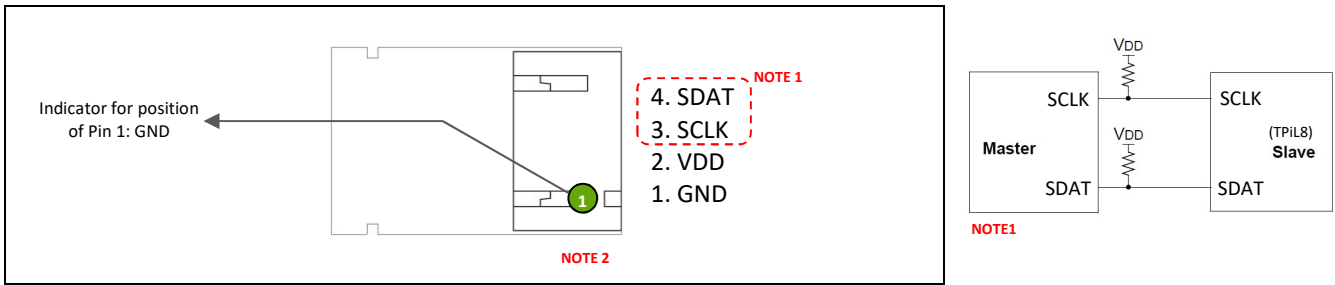

Serial Interface: SMBus & Data Communication Information

A '2-wire', bi-directional SMBus compatible serial interface is provided for communication of sensors' data to and from target applications.

TPiL 8T Application Note: SMBus Communication, provides examples to understand and to operate the SMBus communication protocol. For complete SMBus specification, please refer to the following webpage: www.smbus.org/specs

There are 2 types of memory in the TPiL 8T device:

1. EEPROM – holds configuration data
2. RAM – holds temperature data.

Only READ operation is applicable to RAM data; READ / WRITE operations are applicable to EEPROM data.

The following sub-sections specify the SMBus protocol required to: (1) WRITE Word, and (2) READ Word; according to legend provided here.

- S SMBus START Condition
- Sr SMBus Repeated START Condition
- Rd READ (bit value 1)
- Wr WRITE (bit value 0)
- A ACKNOWLEDGE (ACK)
- Ā NOT ACKNOWLEDGE (NACK)
- P SMBus STOP Condition
- PEC Packet Error Code (CRC: Cyclic Redundancy Check) please see below



Data Direction: MASTER send to SLAVE



Data Direction: SLAVE send to MASTER

SMBus Protocol: WRITE Word

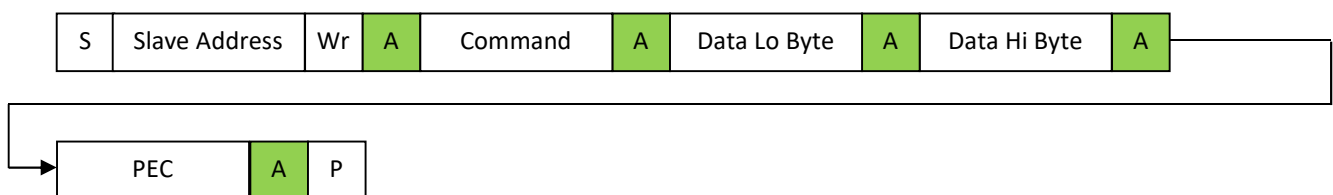

SMBus Protocol: READ Word

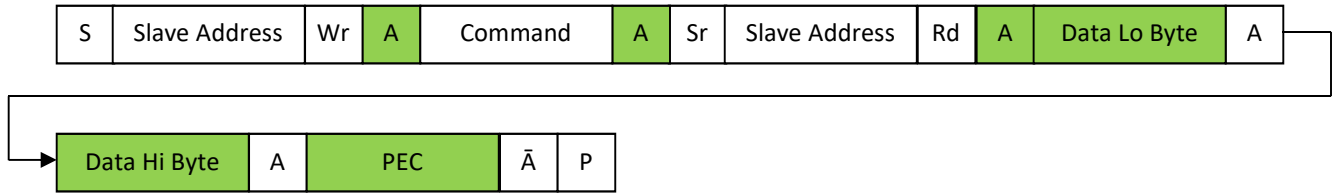

COMMAND

COMMAND is a byte used by the MASTER device to tell the TPiL 8T what data it required. The COMMAND has the following format:

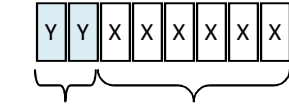

Memory Type Address

Where $\begin{matrix} Y & Y \\ \hline 0 & 0 \end{matrix}$ Means RAM Data
 $\begin{matrix} Y & Y \\ \hline 0 & 1 \end{matrix}$ Means E2P Data

COMMAND	DESCRIPTIONS
00 XXXXXX _{bin}	Read RAM, XXXXXX = 6 LSBits of address of RAM cell to be read
01 XXXXXX _{bin}	Read/Write EEPROM, XXXXXX = 6 LSBits of address of E2P cell to be read/written

NOTE: Addresses of RAM & EEPROM are described in the sections: **OUTPUT DATA INFORMATION** and **CONFIGURATION PARAMETERS & DESCRIPTIONS**

SMBus Protocol : BLOCK READ

In addition to the above READ Word, a BLOCK READ protocol can be activated in order to output in one sequence the data refreshed from RAM Addresses 18 to 26 (T_{AMB}, T_{OBJ_PIX1}, T_{OBJ_PIX2} ... T_{OBJ_PIX8}) by providing a single COMMAND byte ,11XXXXXX_{bin}'.

Where $\begin{matrix} Y & Y \\ \hline 1 & 1 \end{matrix}$ Means RAM (Block) Data

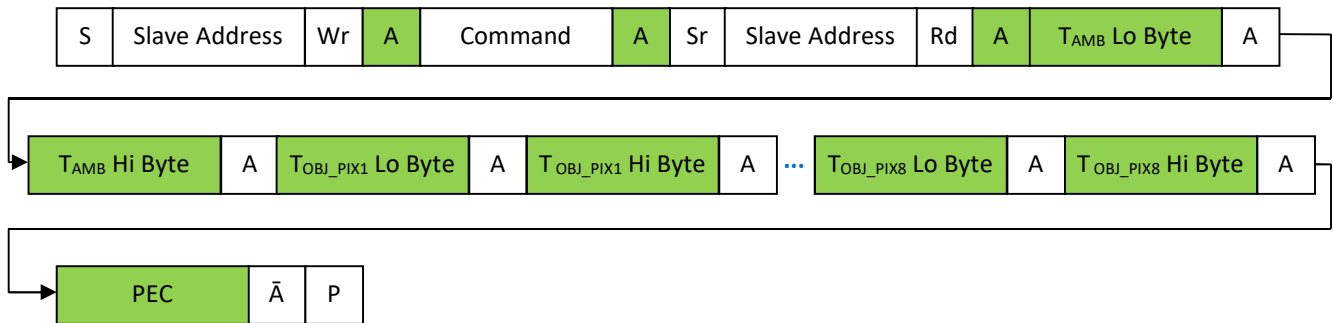

COMMAND	DESCRIPTIONS
11 XXXXXX _{bin}	Block Read RAM, from Address 18 (T _{AMB}) to Address 26 (T _{OBJ_PIX8})

NOTE: Block Read is activated by default !

PEC: CYCLIC REDUNDANCY CHECK

Each bus transaction requires a Packet Error Code (PEC) calculation by both the MASTER and the SLAVE devices to ensure physical correctness of transmitted data. The PEC includes all bits of a transaction except the START, REPEATED START, STOP, ACK, and NACK bits.

The PEC employed by TPiL 8T is a CRC-8 with polynomial $PEC = x^8+x^2+x+1 = 107hex$ and must be calculated in the order of the bits as received.

CLOCK LOW EXTENSION & DATA PREPARATION TIME

The TPiL 8T uses clock low extension, t_{EXT} where necessary in order to extend the low period of SCLK in order to gain time for data processing, or data preparation for transmission.

For this reason, there are also minimum timing conditions represented by data preparation time, t_{Data_Prep} required to ensure reliable SMBus communication with the TPiL 8T.

The diagram below shows the READ Word command as an example. In order to ensure stable SMBus communication, the MASTER Device is required to apply t_{Data_Prep} at the various positions as indicated.

NOTE: t_{EXT} is generated automatically by TPiL 8T, therefore Master Device do not need to apply time delay for these.

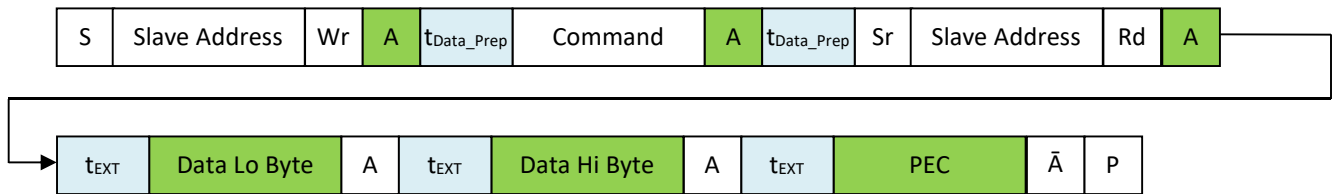

The following table provides the required settings for t_{EXT} and t_{Data_Prep} at specified SCLK frequency's:

SYMBOL	PARAMETER	MIN	TYP	MAX	UNIT	CONDITIONS
t_{EXT}	SCLK signal clock low extension	-	-	100	μs	-
t_{Data_Prep}	Time delay required by Master Device during data preparation	120	-	-	μs	SCLK Frequency = 80kHz
		45	-	-		SCLK Frequency = 50kHz

SMBus Timeout

TPiL 8T provides a Time-out mechanism for SMBus communication self recovery in the event that the SMBus protocol sequence is interrupted or disturbed. Every time a new SMBus transaction is recognized by a Slave Address match, a timer is activated. If the subsequent SMBus protocol events do not occur within a span of 30ms, a Timeout occurs and as a reaction the SMBus communication sequence will be reset to be ready for a new transaction.

SMBus Signals: Timing Characteristics

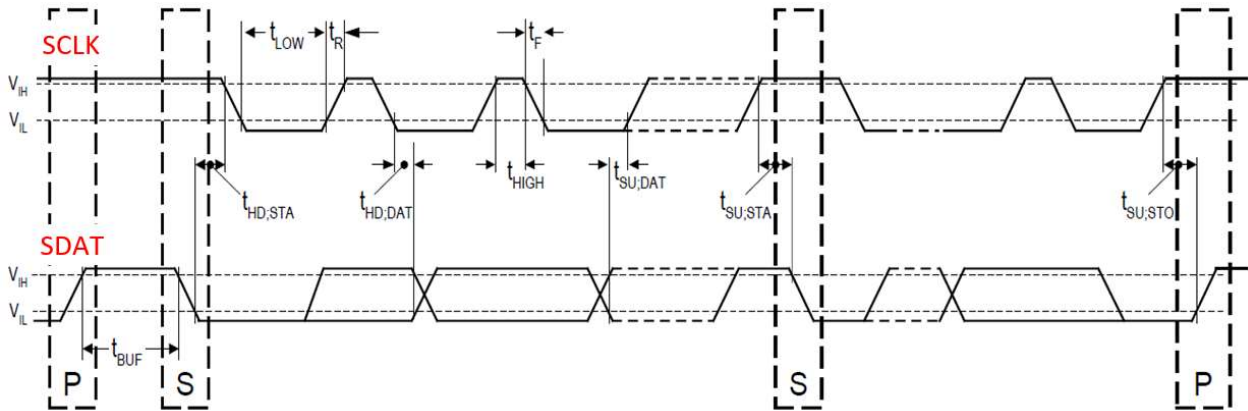

Unless otherwise indicated, all limits are specified for T_{AMB} at 25°C, V_{DD} at 5V.

SYMBOL	PARAMETER	MIN	TYP	MAX	UNIT	CONDITIONS
t _{BUF}	Bus free time between STOP and START condition.	10	-	-	μs	-
t _{HD:STA}	Hold time after (Repeated) START Condition. After this period, the first clock is generated.	4.0	-	-	μs	-
t _{SU:STA}	Repeated START Condition setup time.	4.7	-	-	μs	-
t _{SU:STO}	STOP Condition setup time	4.0	-	-	μs	-
t _{HD:DAT}	Data hold time	300	-	-	ns	-
t _{SU:DAT}	Data setup time	250	-	-	ns	-
t _{LOW}	Clock low period	4.7	-	30000	μs	NOTE 1
t _{HIGH}	Clock high period	4.7	-	50	μs	NOTE 1
t _F	Clock / Data fall time	-	-	300	ns	-
t _R	Clock / Data rise time	-	-	1000	ns	-

NOTE 1: Refer to SMBus Timeout.

Output Data Information

Temperature outputs of the TPiL 8T are updated into the RAM memory. The address(s) of the RAM Data are defined by the following Table:

RAM ADDRESS	BIT	DATA	DESCRIPTION OF DATA	Value Range
0	15 ... 0	VPIX ₀	Amplified Pixel Voltage of dummy Pixel 0: Value = 10000 * VPIX ₀ [in V]	0 ... 50000
1 ... 16 ^{NOTE 1}	15 ... 0	VPIX _[1 ... 16]	Amplified Pixel Voltage of corresponding Pixel i: VPIX _i [in V] = k*(T _{OBJ} ⁴ - T _{AMB} ⁴) Value _i = 10000 * VPIX _i [in V]	0 ... 50000
17	15 ... 0	V _{PTAT}	Amplified PTAT Voltage Value = 10000 * V _{PTAT} [in V]	0 ... 50000
18	15 ... 0	T _{AMB}	Calculated Ambient Temperature: Value = 10 * T _{AMB} [in °C]	0 ... 65535
19 ... 34 ^{NOTE 1}	15 ... 0	T _{OBJ} [1 ... 16]	Calculated Object Temperature (T _{AMB} Compensated): Value = 10 * T _{OBJ} [in °C]	0 ... 65535

NOTE: The data of RAM ADDRESS 0 to 17 is used for factory calibration only and not relevant for customer application.

NOTE 1: The signal processing electronic and the data space in RAM are designed to measure up to 16 sensor pixels / elements. Due to 8 pixels sensor elements, only pixels 1 ... 8 and corresponding addresses are valid. Pixel 1 = Address 19, Pixel 8 = Address 26. Negative temperature output are represented as follows, eg. -5°C → 65535 - 50 = 65485.

T _{OBJ} / °C	T _{OBJ} Output (RAM ADDRESS 19 ... 34) / Value		
	MIN	TYP	MAX
0.0	65510	0	25
5.0	25	50	75
10.0	75	100	125
15.0	125	150	175
20.0	175	200	225
25.0	225	250	275
30.0	275	300	325
35.0	325	350	375
40.0	385	400	415
45.0	425	450	475
50.0	475	500	525
55.0	525	550	575
60.0	575	600	625

NOTE: Accuracy for T_{OBJ} between 25°C and 60°C are measured in Excelitas Lab. For T_{OBJ} below 25°C, accuracy is estimated.

Configuration Parameters & Descriptions

The address(s) of customer accessible EEPROM Data are defined by the following Table:

EEPROM Address	Bits	Name	Meaning	Mode	Value Range
35	6 ... 0	SA	Unique SMBus Slave Address	R/W	0 ... 127 (Default = 0A _{Hex})
	7	-	Not used	-	0
38	7 ... 0	F	Filter Mode: 0 = Filter disabled 2 = Filter enabled	R/W	0 ... 2 (Default = 2)
39	7 ... 0	WEIGHT_PIX	Filter Strength (1% ... 99%) applied to T _{OBJ} signals. Value: 1% - Very strong filter 99% - Very weak filter	R/W	1 ... 99 (Default = 20%)
40	7 ... 0	WEIGHT_PTAT	Filter Strength (1% ... 99%) applied to T _{AMB} signals. Value: 1% - Very strong filter 99% - Very weak filter	R/W	1 ... 99 (Default = 5%)
42	9 ... 0	E	Emissivity Factor Value = 10* Emissivity Factor in %	R/W	0 ... 1000 (Default = 100%)
62, 63	15 ... 0	ID ^{NOTE 1}	Unique Sensor ID identical to corresponding sticker label applied on module	R/W	0 ... 2 ¹⁶

NOTE: Configuration and Calibration changes are scalable. Other EEPROM addresses are locked from changes. Default settings may be optimised and changed in order to fit specific application requirements.

NOTE 1: ID may not apply for engineering samples.

EEPROM Writing

EEPROM Writing is performed asynchronously to SMBus communication. The write cycle time t_{WR} is the time from a valid STOP condition of a WRITE WORD command sequence to the end of physical transfer of received data into EEPROM cell. Please refer to page 2 for specified value of t_{WR} .

Mechanical Information

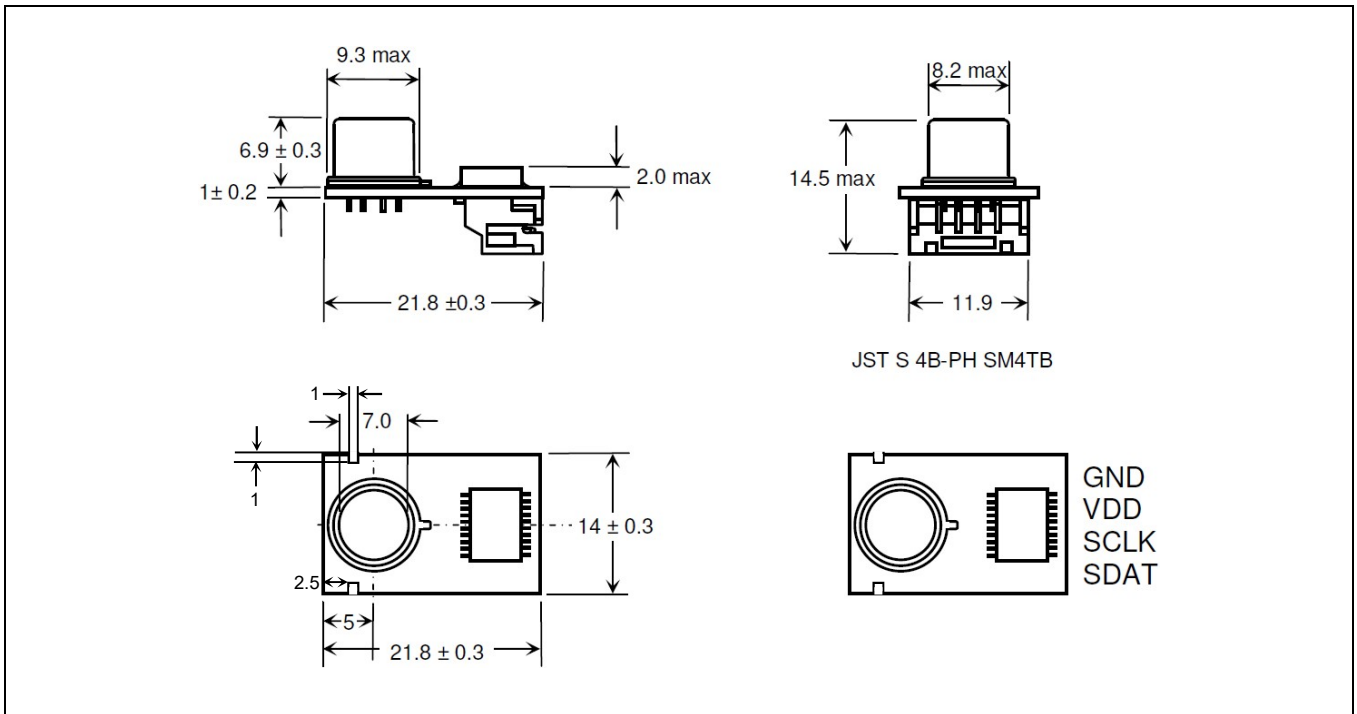

Soldering

The TPiL 8T is a lead-free component and fully complies with the RoHS regulations, especially with existing roadmaps of lead-free soldering.

NOTE: This may not apply for engineering samples.

Labelling

For manufacturing traceability, each sensor and module is labelled using the following format.

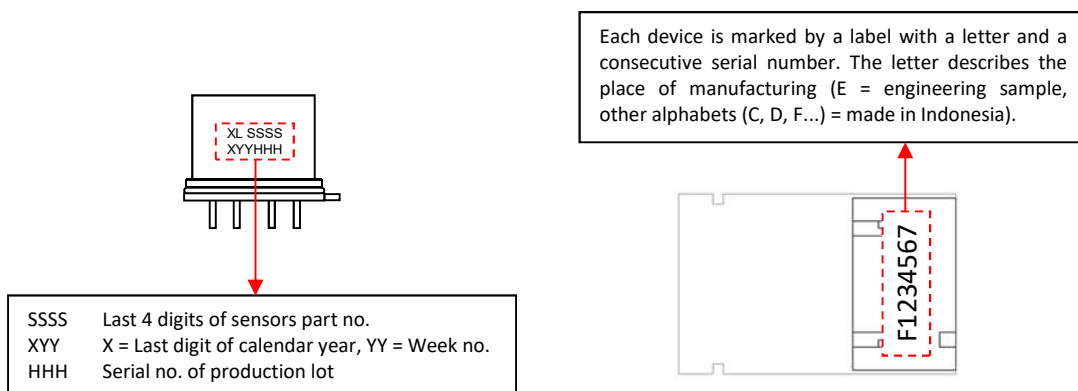

Quality System

Excelitas Technologies is an ISO 9001:2015 certified manufacturer with established SPC and TQM.

Excelitas Technologies is certified for its Environmental Management System according to ISO 14001:2015 and for the Occupational Safety and Health Management System according to ISO 45001:2018.

The PCB assembly and components are of lead-free type, compliant to RoHS.

All devices employing PCB assemblies are manufactured according to IPC-A-610 class 2 guidelines.

The infra-red detection product line is certified for ANSI/ESD S.20.20:2014.

Liability Policy

The contents of this document are subject to change. The details of this document are valid by the specified revision date. Excelitas reserves the right to change at any time total or part of the content of this specifications without individual notification. Customers should consult with Excelitas Technologies' representatives to ensure updated specifications before ordering.

Customers considering the use of Excelitas Technologies devices in applications where failure may cause personal injury or property damage, or where extremely high levels of reliability are demanded, are requested to discuss their concerns with Excelitas Technologies representatives before such use.

The Company's responsibility for damages will be limited to the repair or replacement of defective product. As with any semiconductor device, thermopile sensors or modules have a certain inherent rate of failure. To protect against injury, damage or loss from such failures, customers are advised to incorporate appropriate safety design measures into their product.