

PYD 1798 / 7687



Digital Output Dual Element Large Field-of-View Pyro

The PYD 1798 is a serial opposed format, two elements detector based on pyroceramic. The signal is converted to a digital value using Sigma-Delta and DSP techniques. The data is accessed by the host system through a proprietary one-wire interface to enable advanced signal analysis with your own detection criteria.

The sensor is operating down to 1.8V. The power consumption is typically 5 μ A at 3.3V.

Excelitas digital solutions provide excellent EMI immunity.



Product Specification

Features

- Integrated digitization
- Ultra-low power consumption of typ. 5 μ A at 3.3 V
- Min supply voltage of 1.8 V
- High responsivity ceramic pyroelectric elements
- Dual detector with $2 \times 1 \text{ mm}^2$ elements
- 120° field-of-view
- TO-5 metal housing for high EMI immunity
- Best for advanced motion detection algorithms

Applications

- Long distance motion detection (with lens)
- Energy saving applications
- Intrusion alarms
- Horizontal mounting applications
- Battery operation

Contents

1 Physical Characteristics	3
1.1 Pyro-Electric Elements	4
1.2 Optical Properties	5
1.3 Filter Properties	6
2 Electrical Characteristics	7
2.1 Absolute Maximum Ratings	7
2.2 Electrical Data	7
2.3 Interface Overview	9
2.4 Direct Link Interface	10
3 Handling, Operation and Precautions	12
3.1 Handling	12
3.2 Operation	12
4 Quality and Statements	13
5 Packaging	14

1 Physical Characteristics

Table 1: Summary of physical characteristics. Parameters and data refer to an ambient temperature of $25 \pm 3 \text{ }^\circ\text{C}$.

Parameter	Symbol	Min	Typ	Max	Unit	Remarks/Conditions
Housing			TO-5			see fig. 1
Lead Length			13.2		mm	see fig. 1
Field of View	FOV		120		$^\circ$	see sec. 1.2
Element Size			2×1		mm	see fig. 1
Spacing			1		mm	see fig. 1
Optical Distance			700		μm	see fig. 1
Responsivity	R	3.3	4.0		kV W^{-1}	see sec. 1.1
Match	$(R_A - R_B)/R_A$			10	%	see sec. 1.1
Noise			20	78	μV_{pp}	see sec. 1.1
IR-Filter			Standard			see sec. 1.3

Figure 1: Dimensions and Connections. Explanations follow in this document.

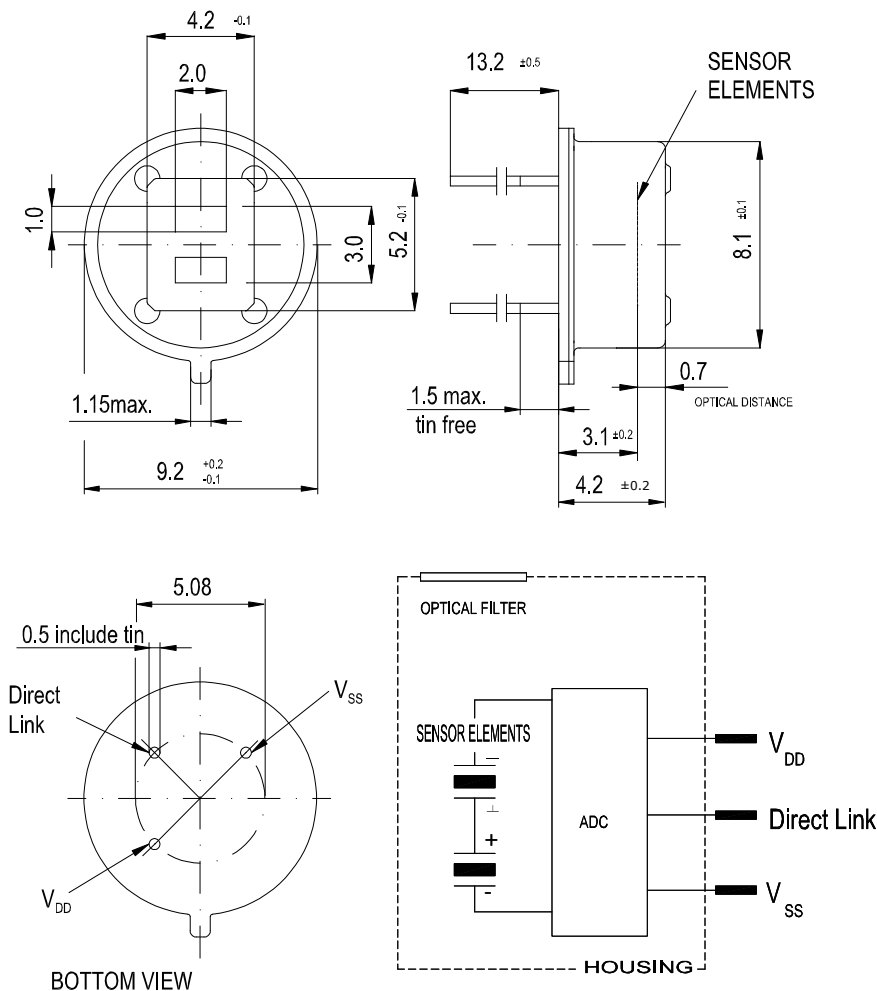

1.1 Pyro-Electric Elements

The element configuration is shown in figure 1. It features a dual element configuration in a serial opposed format. Its typical application is long distance, wall mounted, motion detection .

Figure 2: Test set up for the measurement of responsivity and match.

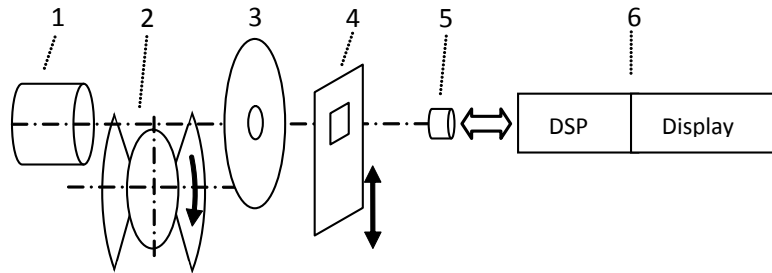
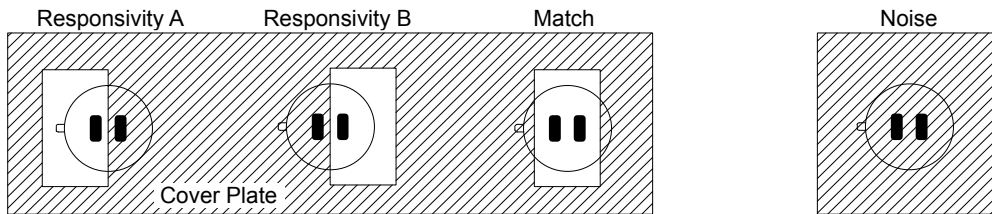

Figure 3: Masking of elements to test the electrical parameters.



The typical set-up for the measurement of responsivity and match is illustrated in figure 2. The black body (BB) radiator (1) is set to 373 K (100 °C). The signal is modulated by a rotating chopper (2). An aperture (3) is used to adjust the radiation flux. The cover plate (4) is masking the elements as shown in figure 3. The sensor (5) is interfaced to a signal processing chain (6). To measure noise, a bandpass filter in the range of 0.4 Hz to 10 Hz is applied.

Responsivity (*R*) and match are measured at a modulation frequency of 1 Hz.

The match is defined by

$$\frac{\text{Match}}{R} \times 100 \tag{1}$$

Noise is measured shut from infra-red energy. The measurement is performed after a settling time of 10 min at an ambient temperature of 25 °C ± 3 °C. Noise is monitored for the duration of 600 s .

1.2 Optical Properties

Figure 4: Illustration for the definition of the horizontal field of view (FOV).

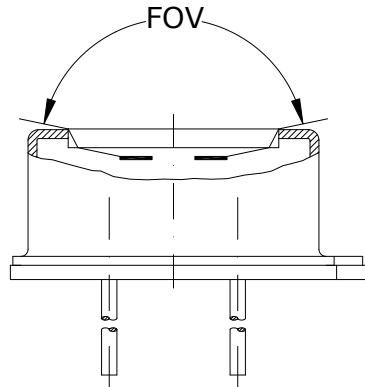

The horizontal field of view (FOV) as drawn to figure 4 is given as the geometrically unobstructed light path to both elements. The FOV of 120° is given for the optical light acceptance with the full so-called common mode suppression.

The optical distance as it is given in figure 1 represents the effective focal plane for the application specific optics. The optical distance is shorter than the geometrical due to refraction of light in the filter.

1.3 Filter Properties

Table 2: Filter properties

Parameter	Symbol	Min	Typ	Max	Unit	Remarks/Conditions
Average Filter Transmittance	T_A	77			%	$7.5 \mu\text{m} < \lambda < 13.5 \mu\text{m}$
Average Filter Transmittance	T_A			0.5	%	$\lambda < 5 \mu\text{m}$
Cut-on Wavelength	$\lambda(5\%)$	5.2	5.5	5.8	μm	at 25 °C

Figure 5: Filter transmittance, typical curve

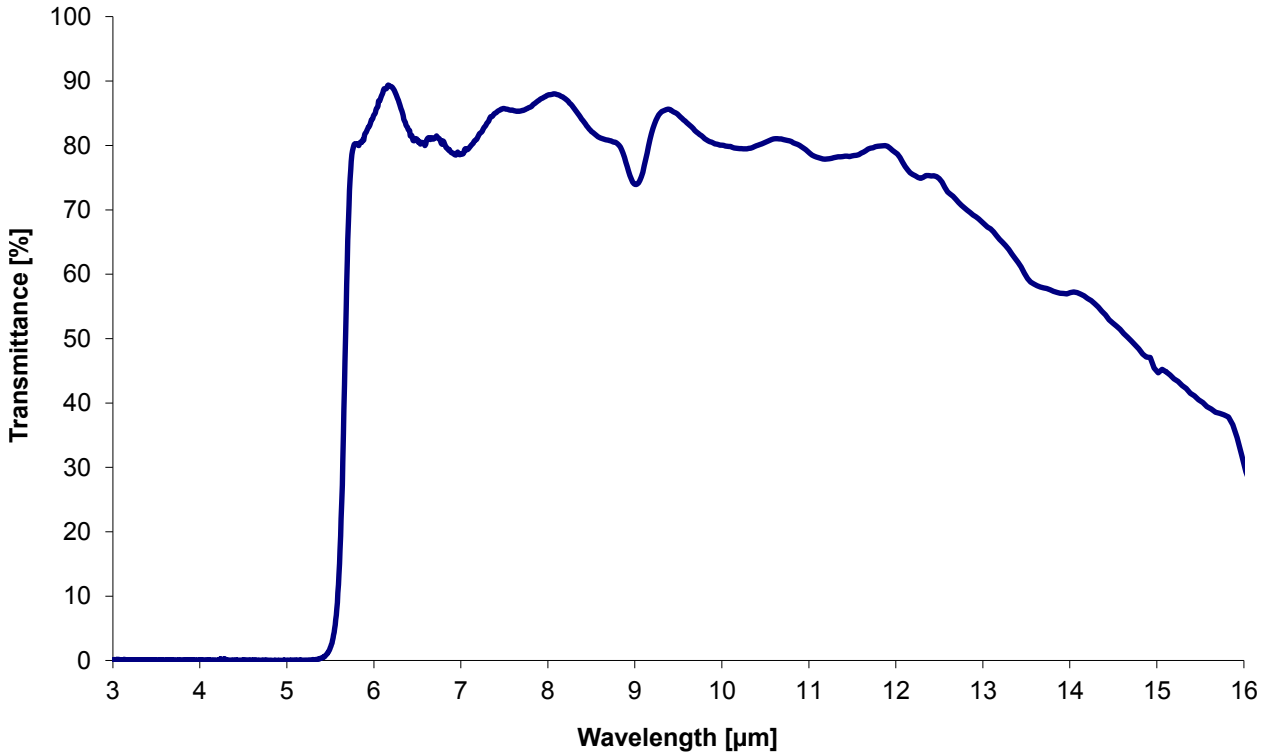

2 Electrical Characteristics

2.1 Absolute Maximum Ratings

Table 3: Absolute Maximum Ratings. Data applicable to operation at free-air temperature range.

Parameter	Symbol	Min	Typ	Max	Unit	Remarks/Conditions
Voltage at any pin	V_{DD}	-0.3		3.6	V	
Current into any pin	I_{pin}	-100		100	mA	
Storage Temperature		-40		85	°C	< 60 % r.H.
Operating Temperature		-40		70	°C	

Stresses beyond the limits listed in table 3 may cause permanent damage to the device. Exposure to absolute maximum ratings for long time may affect the device reliability and may lead to deterioration of any parameter.

2.2 Electrical Data

Table 4: Electrical Data. Unless specified differently all data refers to 25 ± 3 °C.

Parameter	Symbol	Min	Typ	Max	Unit	Remarks/Conditions
Operating Voltage	V_{DD}	1.8	3.3	3.6	V	
Supply Current	I_{DD}		5	7	µA	$V_{DD} = 3.3$ V, no load
Direct Link						
Input Low Voltage	V_{IL}			$0.2V_{DD}$	V	
Input High Voltage	V_{IH}	$0.8V_{DD}$			V	
Input Current ²	I_I	-1		1	µA	
Data Setup Time	t_{DS}	75		200	µs	Interrupt Readout Mode
Data Setup Time	t_{DS}	110		200	µs	Forced Readout Mode
Data Clock Low Time	t_{DL}	200		2000	ns	
Data Clock High Time	t_{DH}	200		2000	ns	
Data Bit Settling Time	t_{BS}			2	µs	$C_{LOAD} < 10$ pF
Sample Time	t_{SMPL}	2.0		14.6	ms	
Bit Time	t_{BIT}			25	µs	
Update Time	t_{UP}	1250			µs	
ADC Resolution ¹			14		Bits	
PIR ADC Sensitivity			6.5		µV/Count	
PIR ADC Offset		6500	8192	9800	Counts	in stable condition
Sensitivity of T_{AMB}		72	80	88	Counts/K	
Counts at 25 °C		4400	6700	9000	Counts	
LPF cutoff frequency	f_1		7		Hz	
Internal Clock Frequency	f_{CLK}	29	32	35	kHz	

¹ Effective ADC range is from 511 counts to $2^{14} - 511$ counts.

² Pull Up/Down resistors at Direct Link are not applicable.

³ It is not recommended to use a resistor in series above 500 Ω and/or decoupling capacitors larger than 50 pF.

2.3 Interface Overview

Figure 6: Block Diagram

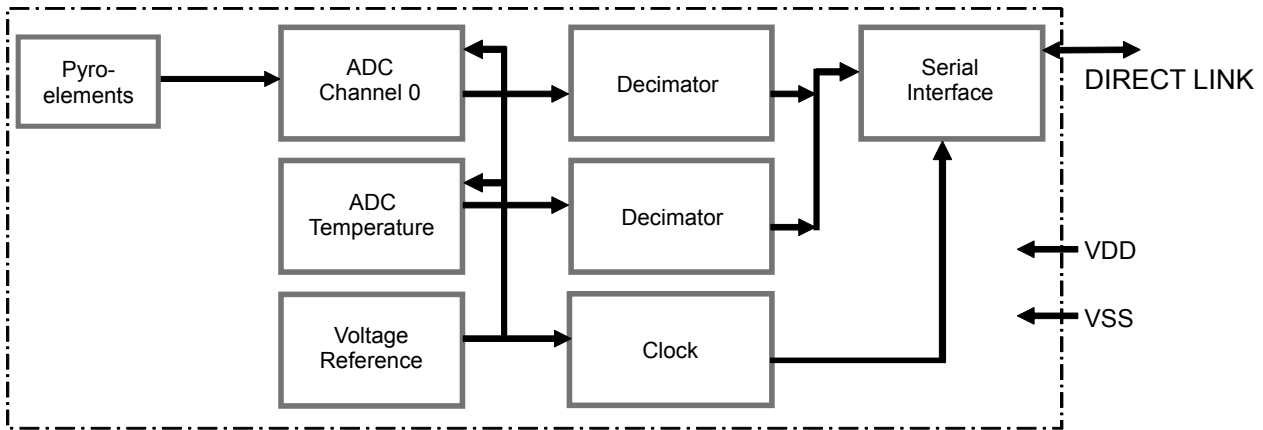

The pyro-electric sensing elements are connected to a built-in IC, whose functions are shown in the block diagram 6. The DigiPyro™, contains pyro-electric elements, sensitive to IR radiation, and an ASIC for the digital signal processing within the sensor package. The ASIC includes an on-chip oscillator, a voltage reference, an analog-to-digital (ADC) converter for the pyroelements and an internal temperature sensor. A proprietary serial interface called "DIRECT LINK" is used to read the digitized data.

2.4 Direct Link Interface

The DIRECT LINK interface is a bi-directional one wire serial interface which is used to continuously retrieve data from the sensor.

Table 5: Content of the DIRECT LINK data stream when reading sensor out.

Bit#	Description	Size[bit]	Remarks
[27:14]	PIR (CH0) ADC counts	14	Value of PIR
[13:0]	Temperature ADC counts	14	Value of internal temperature reference

Out of Range The ASIC features an out of range detection. Should the pyroelectric sensor’s signal drop below 511 counts or exceed $2^{14} - 511$ counts, the input will be shorted for a duration of about 16ms in order to discharge the sensor. Out of range conditions may occur for example during strong sensor temperature gradients of more than 1 K min^{-1} .

ADC counts The data represents ADC counts after low-pass filtering and the reference temperature counts. The low-pass data and the reference temperature data is represented as 14 bit unsigned integer. We recommend to implement a band pass filter on the hostsystem for the PIR data prior to further data analysis to remove the DC (offset) component.

Figure 7: Data Transmission Diagram

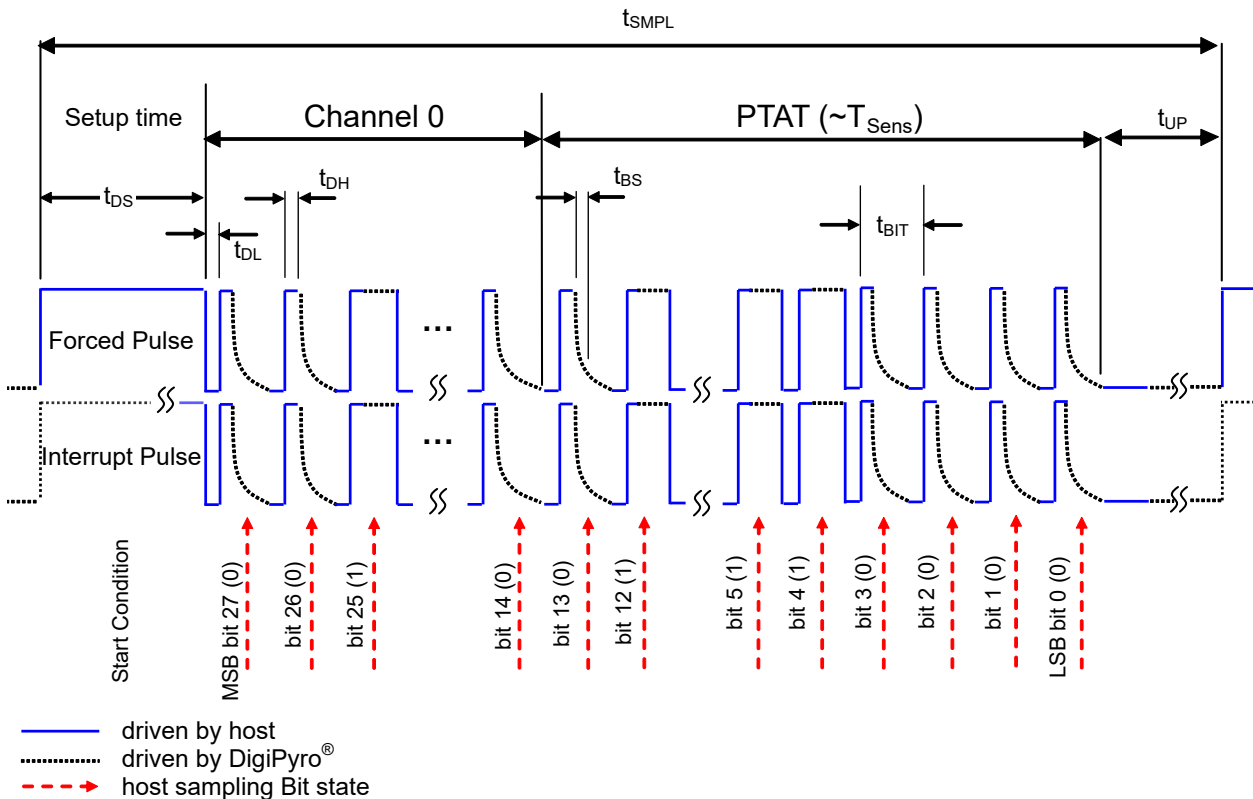

Timing The DIRECT LINK interface communication principle is sketched in figure 7. It can be divided into the start condition and the data stream after it.

The start condition for any communication is indicated by a LOW to HIGH transition of the DIRECT LINK line. That condition can be initiated either by the host system or the sensor. Initiating the condition with the host system is called "Forced Readout" mode. Initiating the condition with the sensor is called "Interrupt (driven) Readout" mode. The sensor will periodically initiate an "Interrupt Readout" if no "Forced Readout" is initiated by the host system. Details are described below.

Forced Readout The sensor is expecting the host system to initiate the communication. Forcing DIRECT LINK to HIGH for at least $t_{DS} = 110 \mu s$ and then pulling it to LOW will start the communication. The host system can resume with the **Readout of Bits**.

If the host system is not initiating the communication for a period of longer than $t_{SMPL} = 14.6 \text{ ms}$ the sensor will pull the line HIGH to initiate the "Interrupt Readout".

Interrupt Readout The sensor will drive the line typically every $t_{SMPL} = 16 \text{ ms}$ HIGH. The host system must then pull the line to LOW in order to start the communication with the sensor. The host system can proceed to the **Readout of Bits** not sooner than $75 \mu s$ after the Interrupt occurred and the DIRECT LINK was HIGH.

In order to recognize the interrupt by the sensor, the host system's connection to the DIRECT LINK line must have a high impedance (high Z) and be set to input.

The recommended readout mode is the "Forced Readout".

Readout of Bits The readout procedure is started by the forced or interrupt pulse. The DigiPyro™ waits for the next LOW to HIGH transition by the host system. The host system pulls the line HIGH and releases it (high impedance Z). The DigiPyro™ will pull the line LOW for a 0 bit state or keep it HIGH for a 1 bit state.

The time t_{BS} which the signal needs to settle to a LOW level depends on the capacitive load (e.g. PCB design) at the DIRECT LINK pin. Hence, it is recommended to start implementing the interface with t_{BIT} close to, but shorter than $25 \mu s$ to ensure proper LOW level settling. In next steps reduce t_{BIT} empirically to optimize for reliable data transmission at maximum transmission speed. It is not recommended to choose bit settling times below $2 \mu s$.

After reading the line state by the host system, the host pulls the line again LOW to initiate the next bit readout by a LOW to HIGH transition again. The sequence will be repeated until all bits are shifted out. After the last bit of bit[0] the host controller must force DIRECT LINK pin to LOW for at least $t_{UP} > 1250 \mu s$ and subsequently release DIRECT LINK (High Z). This minimum time is required to allow the registers to be updated with latest values before the next read operation.

It has to be considered that t_{BIT} must not exceed $25 \mu s$ to avoid data corruption. Under no circumstances DIRECT LINK may be at LOW level for longer than $25 \mu s$, in case further bits need to be read out. It is recommended that the total time to readout one data packet should not exceed $800 \mu s$ to ensure always latest values. In "Interrupt Mode" the total readout procedure must not exceed $t_{SMPL} < 14.6 \text{ ms}$.

It is allowed to cancel the readout at any position of the data stream. To terminate the readout, DIRECT LINK must be forced to LOW level and kept for at least $t_{UP} > 1250 \mu s$ in order to ensure an update to latest values.

In order to reduce settling effects, the data packets have to be read continuously with equal sampling intervals.

3 Handling, Operation and Precautions

3.1 Handling

Shelf Life The product can be stored for 12 months before usage at $-10^{\circ}\text{C}..40^{\circ}\text{C}$ (<60% r.H. at 40°C non condensing).

Storage Avoid storage under high humidity and/or high ambient temperature environments.

ESD The ASIC was designed to withstand a discharge of up to 1.6 kV through a $1.5\text{ k}\Omega$ resistor in series according to the test method MIL-STD-883D / 3015.

Handle the detectors as ESD sensitive devices and protect them from electrostatic discharges. Working areas should be conductive and grounded. When handling detectors, operators shall be grounded.

Mechanical Avoid mechanical stress on the housing and especially on the leads. Be careful when cutting or bending leads to avoid damage. Do not bend leads less than 5 mm from their base. Do not drop detectors on the floor.

Cleanliness Avoid touching the detector window. To clean windows, use only ethyl alcohol with a cotton swab when necessary. Do not expose detectors to aggressive detergents such as Freon, trichloroethylene, etc.

Soldering Conditions For the soldering of the detectors within PCBs, the typically applied and recommended process is wave soldering. The recommended soldering temperature shall not exceed 285°C with a maximum exposure time of 5 seconds. During the automatic wave solder process we strongly advise to restrict preheating when the detector is directly exposed to the radiation of such heaters. In this case, the detector should be protected from the heat.

Manual soldering is also possible when maintaining similar temperature profiles.

Re-flow soldering is not possible due to the high temperature profiles of the process.

Temperatures higher than recommended may affect its performance. Any soldering process should be qualified to avoid damage to the sensor.

3.2 Operation

Humidity The operation below the dew point may affect the performance.

Temperature Strong temperature gradients above 1 K min^{-1} may affect the sensor's performance. Before taking a reading, during testing, and / or operation the unit has to become thermally stable (due to its nature as a thermal detector and the high sensitivity of the device).

All data is specified at room temperature. When operating at other temperatures within the specified operating range, parameters may vary. The detectors might operate outside the quoted range but may have degraded performance.

4 Quality and Statements

Quality Excelitas Technologies is a ISO 9001:2015 certified manufacturer with established SPC and TQM. Detector out-going inspections include the parameters responsivity, match, offset, noise, gross leak. Due to high level mass production, individual data is not stored.

Excelitas Technologies is certified for it's Environmental Management System according to ISO 14001:2015 and for the Occupational Safety and Health Management System according to ISO 45001:2018.

All devices employing PCB assemblies are manufactured according IPC-A-610 class 2 guidelines.

The infra-red detection product line is certified for ANSI/ESD S.20.20:2014.

Package This IR-detector is sealed to pass a He-leakage test with maximum leak rate of 1×10^{-8} mbar l s⁻¹.

Tracability The marking of the detector includes the principal type, a 4 digit number that represents the Excelitas identification number. A 4 digit date code is provided in addition to that. It consists of the production year and week. The marking is printed on the top or side of the detector.

Safety Modern high-tech materials are applied in the production of our pyro-electric detectors. Some of these materials are sensitive to high temperature exposure or to specific forms of stress. Our parts are compliant with environmental regulations such as RoHS 2011/65/EU. For details please contact our local representatives. We recommend to always check your local regulations. Disposal shall only be carried out in accordance with the latest legislation and directives. In Europe, WEEE directives must be followed.

The leads of these detectors have been pre-tinned with lead free tin process and may be applied through lead-free solder processes. As such the detectors will enable the design of RoHS compliant products.

Liability Policy The contents of this document are subject to change. The details of this document are valid by the specified revision date. Excelitas reserves the right to change at any time total or part of the content of this specifications without individual notification. Customers should consult with Excelitas Technologies' representatives to ensure updated specifications before ordering.

Customers considering the use of Excelitas Technologies devices in applications where failure may cause personal injury or property damage, or where extremely high levels of reliability are demanded, are requested to discuss their concerns with Excelitas Technologies representatives before such use.

The Company's responsibility for damages will be limited to the repair or replacement of defective product. As with any semiconductor device, thermopile sensors or modules have a certain inherent rate of failure. To protect against injury, damage or loss from such failures, customers are advised to incorporate appropriate safety design measures into their product.

5 Packaging

The Excelitas Technologies tube packaging system protects the product from mechanical and electrical damage and is designed for manual unloading. Figure 8 shows the basic outline.

The system consists of tubes which are protected against ESD (5). The devices are loaded sequentially and fixed with stoppers (4). Up to 50 parts are filled into one tube. In total up to 20 tubes are placed in one paper box (3) filled with protective sponges (8,9,10).

Information labels, ESD labels and bar-code Labels (7) are placed on the box. The label (7) contains the following Information:

- Producer = Excelitas Technologies
- Origin
- Product Name
- Full BAU (unique identification) number
- Batch Number
- Packaging Date

Figure 8: Information about the packaging of sensors.

