



MVS-5000
MVS-5000-UV SERIES
MACHINE VISION STROBE
OPERATION MANUAL

Excelitas Technologies
35 Congress St., Salem, MA 01970 USA
Phone: (978)745-3200 FAX: (978)745-0894
Toll Free: (800)950-3441 in USA only
Website <http://www.excelitas.com>

**WARNING!**

The MVS-5000 produces lethal voltages. Ensure that input power is disconnected and storage capacitors have been discharged before beginning any inspection or internal adjustment.

**WARNUNG!**

Das MVS-5000 erzeugt lebensgefährliche Spannungen. Es muss deshalb darauf geachtet werden, dass der ankommende Strom ausgeschaltet ist und die Ladekondensatoren entladen sind, bevor Kontrollen oder Regelungen am Gerät unternommen werden!

ATTENTION!

Le MVS-5000 fournit des tensions dangereuses. Veuillez vérifier que la prise de courant est déconnectée et les condensateurs d'accumulation sont déchargés avant d'entreprendre des inspections ou des réglages sur l'appareil.

WARNING!

The MVS-5000-UV Machine Vision Strobe produces potentially harmful ultraviolet radiation which can cause severe eye damage. Personnel who may be exposed to its output should wear protective eyewear and clothing at all times.

TABLE OF CONTENTS

	PAGE
1. INTRODUCTION _____	2
1.1. DESCRIPTION _____	2
1.2. UNPACKING _____	3
2. SPECIFICATIONS _____	3
3. INSTALLATION _____	5
3.1. MOUNTING _____	5
3.2. SAFETY REQUIREMENTS _____	5
4. OPERATION _____	7
4.1. CONTROL _____	7
4.2. INPUT CONNECTIONS _____	7
5. MAINTENANCE _____	7
5.1. REPAIRS _____	7
5.2. FLASHTUBE REPLACEMENT _____	8
5.3. REPACKING AND STORAGE _____	9

FIGURES

FIGURE 1. MVS-5000 MACHINE VISION STROBE _____	2
FIGURE 3. SIGNAL INPUT CONNECTOR _____	7
FIGURE 4. FLASHTUBE ORIENTATION _____	9

TABLES

TABLE 1. OPTICAL SPECIFICATIONS _____	3
TABLE 2. ELECTRICAL SPECIFICATIONS _____	4
TABLE 3. MECHANICAL SPECIFICATIONS _____	4
TABLE 4. ENVIRONMENTAL SPECIFICATIONS _____	4
J1 _____	7

1.0 INTRODUCTION

1.1. DESCRIPTION

The MVS-5000 Machine Vision Strobe (hereafter referred to as "the 5000") is a source of short duration, high intensity light pulses for industrial vision applications.

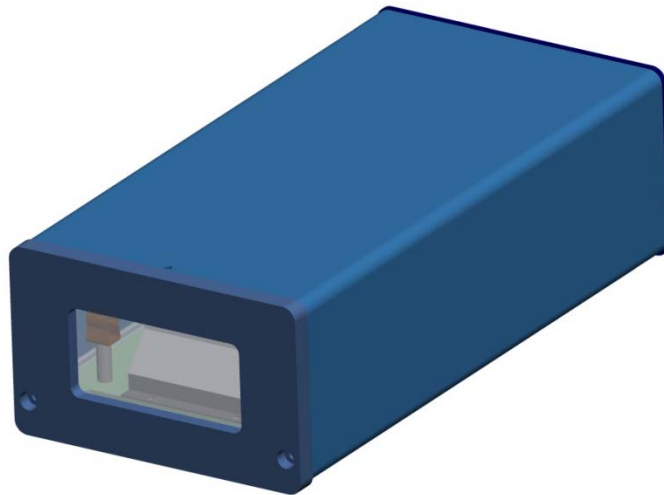

Figure 1 - MVS-5000 Machine Vision Strobe

The 5000 is a DC-powered unit packaged within a metal enclosure with a glass diffusion window. Major components include: a power supply board, a cooling fan, a quartz flashlamp and a reflector. Input power and signal level cable connections are made through a 9-pin sub D connector mounted on the back of the unit. See specification tables for more information.

The strobe can be used for a wide variety of industrial robotics production applications, including: Sorting • Package integrity verification • Counting • Label reading • Contaminant detection • Motion Sensing • Part recognition • Component Orientation • Edge detection • Quality assurance • Color differentiation

1.2. UNPACKING

If the condition of the outer packaging suggests mishandling has occurred, examine the unit for any signs of breakage during shipment. If there are any obvious signs of damage, contact the carrier immediately and do not proceed with the installation.

It is suggested that the packaging material be retained and stored in the event that the unit has to be reshipped.

2.0 SPECIFICATIONS

Table 1 - Optical Specifications

	MVS-5002	MVS-5000	MVS-5004
Spectral bandwidth	300 to 1100+ nanometers	300 to 1100+ nanometers	300 to 1400+ nanometers
Flash rate	15pps maximum	30pps maximum	60pps maximum
Flashlamp life	1 x 10 ⁸ flashes to 50% of initial light output	1 x 10 ⁸ flashes to 50% of initial light output	1 x 10 ⁸ flashes to 50% of initial light output
Flash duration (1/3 peak)	<28 microseconds typical	20 microseconds typical	15 microseconds typical
Flash to flash variation	<5%	<5%	<5%
Light output: Photometric (at 2 feet) Radiometric	3.00 x 10 ⁻³ lumen-sec/cm ² 2.28 x 10 ⁻⁵ joules/cm ²	1.63x10 ⁻³ lumen-sec/cm ² 1.33 x 10 ⁻⁵ joules/cm ²	.8x10 ⁻³ lumen-sec/cm ² .7 x 10 ⁻⁵ joules/cm ²

	MVS-5000-UV	MVS-5010-UV
Spectral bandwidth	290-400 nanometers	290-400 nanometers
Flash rate	30pps maximum	15pps maximum
Flashlamp life	1 x 10 ⁸ flashes to 50% of initial light output	1 x 10 ⁸ flashes to 50% of initial light output
Flash duration (1/3 peak)	20 microseconds typical	<28 microseconds typical
Flash to flash variation	<5%	<5%
Light output: Photometric (at 2 feet) Radiometric	1 x 10 ⁻⁷ joules/cm ²	1.9 x 10 ⁻⁷ joules/cm ²

Table 2 - Electrical Specifications

	MVS-5002	MVS-5000	MVS-5004
Input voltage	11 to 15VDC	11 to 15VDC	11 to 15VDC
DC Input current (RMS)	<4.5A at 12VDC (15Hz)	<4.5A at 12VDC (30Hz)	<4.5A at 12VDC (15Hz)
Input energy per flash	2.88 Joules typical	1.44 Joules typical	0.72 Joules typical
Trigger: Pulse Duration	+5V* pulse 10 to 100 microseconds	+5V* pulse 10 to 100 microseconds	+5V* pulse 10 to 100 microseconds

Table 3 - Mechanical Specifications

Dimensions (Fig. 2)	8.43"L x 4.18"W x 2.52"H (214mm x 106.2mm x 64mm)
Diffusion window	2.5"W x 1.38"H (63.5mm x 34.9mm)
Weight	2 lbs. (0.9 kg)

Table 4 - Environmental Specifications

Operating temperature	32°F to 104°F (0°C to +40°C)
Storage temperature	-40°F to +194°F (-40°C to +90°C)
Ventilation	Forced-air cooling. <i>(Note: Do not block vent holes on underside of enclosure which are needed for air cooling.)</i>
Humidity	0 to 95%
Altitude	6,000 ft (1.8Km)
Polution Degree	1 Indoor use only

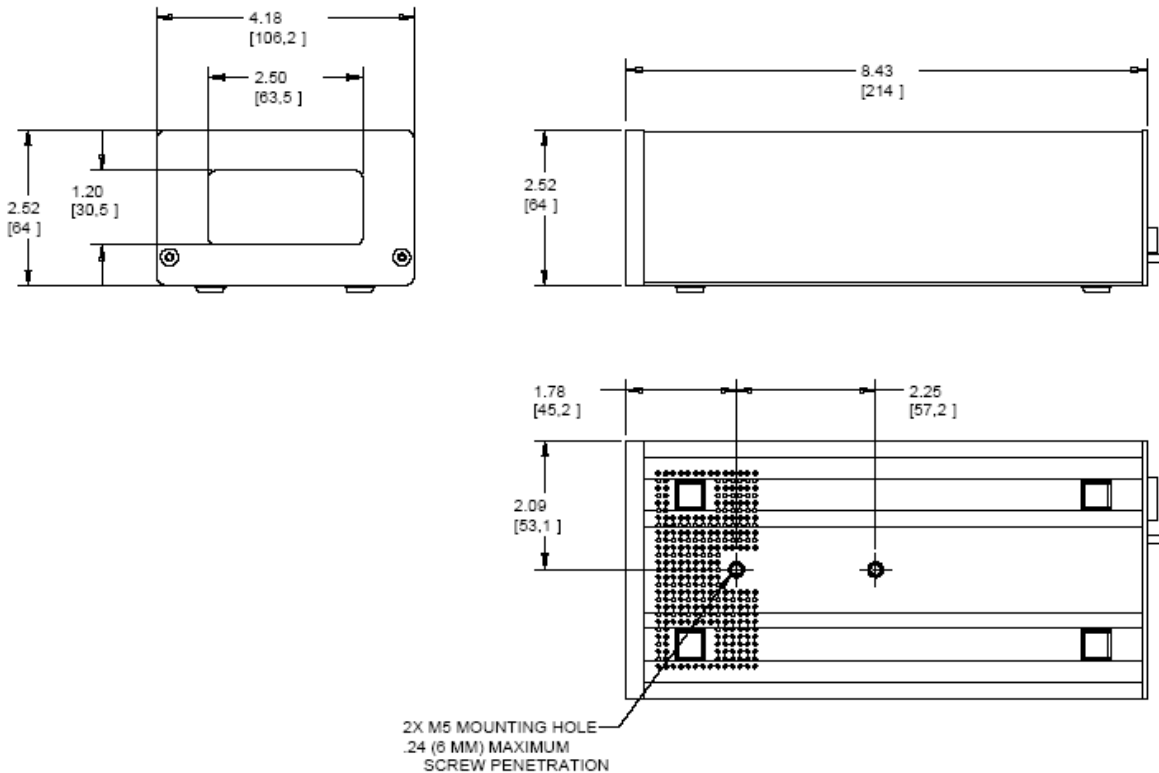

Figure 2 - Outline and Mounting Dimensions

3.0 INSTALLATION

3.1. MOUNTING

Two M5 threaded holes are provided on the bottom of the enclosure for mounting the unit to a suitable structure. (see Figure 2). Attaching the unit to a tripod allows for greater flexibility in placement around the area to be illuminated. Mounting hardware is user-supplied. The mounting screws must be limited in length such that it does not penetrate the case by more than .24 inches or 6mm.

3.2. SAFETY REQUIREMENTS

Shut off input power and disconnect **J1** to remove any possibility of electrical input, particularly when accessing the unit's interior to replace the lamp. Orient the unit so that J1 is accessible.

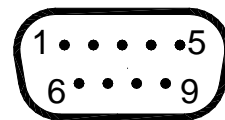

Protect the unit by connecting the user's ground to pins 8 and 9 of **Input Receptacle, J1**.

Be careful not to touch the output window, which can get very hot. The window will break if treated in a manner inappropriate for glass.





WARNING!

The normal operation of this product involves high voltages which are potentially lethal.



Because this product is only one component of a system, and, once sold is exclusively under the control of the user, it has the potential of being used in a manner outside the intended purpose of PerkinElmer Optoelectronics design.

It is essential that the operating specifications and parameters described in PerkinElmer literature and those accompanying other manufacturer's components be observed and not be exceeded under any conditions.

To install or operate this product in a manner for which it is not intended may cause personal injury or death, as well as severe damage to the product and/or other system components.

4.0 OPERATION

4.1. CONTROL

The 5000 strobe has no external controls or adjustments. It delivers a light pulse of fixed intensity in response to each trigger input pulse.

4.2. INPUT CONNECTIONS

The 9-pin connector is used to attach a cable for trigger and reference voltage inputs. A mating connector is supplied. Use a shielded cable, 90% coverage or better, 360° terminated to the back of the shell. The conductors shall be 20 AWG minimum for +/-VDC and 24 AWG minimum for all others. All insulation must be rated for 85 °C and 150Vac minimum. Secure the cable within 12 inches (30.5 cm) of the strobe. A power disconnect switch should be located within 24 inches (61 cm) of the Strobe. It must be rated for 7 Adc at 15V minimum.

Pin 1*	+VDC
Pin 2*	+VDC.
Pin 3	No Connection
Pin 4	- Trigger: opto-isolator trigger return
Pin 5	+Trigger: opto-isolator trigger input; +5v, 20mA; triggers on rising edge.
Pin 6*	-VDC
Pin 7*	-VDC
Pin 8	Chassis ground
Pin 9	Chassis ground

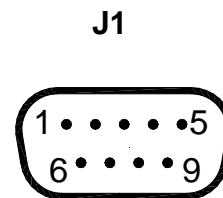

Figure 3 - Signal Input Connector

*To ensure current capability, be sure to connect pin 1 to pin 2 and pin 6 to pin 7.

Connect the signal level input cable to a source that will provide TTL pulses to initiate flashes.

5.0 MAINTENANCE

5.1. REPAIRS

No routine maintenance or repair is required or authorized, except for replacement of the flashtube.

The unit is protected by a 7A slo-blow fuse. If this fuse opens, do not replace it. Return the unit to the factory for repair. In the event that the unit stops functioning properly (other than flashtube end of life), it is strongly suggested that no attempt be made to troubleshoot. Field repairs or customer modifications are not authorized, and, if attempted, will void the warranty. Repairs must be made only by factory-trained personnel. Return the unit to Excelitas Technologies.

5.2. FLASHTUBE REPLACEMENT

Over a period of time (depending on usage), the xenon flashtube may gradually deteriorate and have to be replaced.

	<p>WARNING!</p> <p>The xenon flashtube is a high pressure, gas-filled device. Wear safety glasses when replacing it.</p>
---	---

Replacement lamps are available directly from Excelitas Technologies or our authorized distributors listed below. Order part number FXQG33-1.75

<p>Salem, MA USA Excelitas Technologies 35 Congress Street Salem, MA 01970 Telephone: 978-745-3200 Toll free: (800) 950-3441 (USA) Fax: 978-745-0894 Email: opto@excelitas.com www.excelitas.com</p>

<p>Vision Light Tech Protonenlaan 22 NL-5405 NE UDEN The Netherlands Telephone: +31 (0)413 260067 Fax: +31 (0)413 260938 Email: info@vlt.nl</p>
--

To replace the flashtube, proceed as follows:

1. **Shut off the input power to the strobe.**
2. Wait 120 seconds to allow energy storage capacitors to discharge prior to disconnecting the power/signal cable from the J1 connector (rear panel).



Removing the front panel for access to the flashtube is not required or recommended.

3. Loosen and remove two screws at the bottom corners of the **rear** panel.
4. While grasping the rear panel, slide the PC-5000 Printed Circuit module out of the enclosure to fully exposing the flashtube and reflector.
5. To remove the lamp, gently grip the lamp between the thumb and index fingers while removing the flashtube out of the retainers, one end at a time.
6. Discard the defective flashtube.
7. To reinstall a new FXQG33-1.75 flashtube, gently grip the lamp between the thumb and index fingers and smoothly insert each end of the flashtube into place in the retainers, one side at a time. (Figure 4).

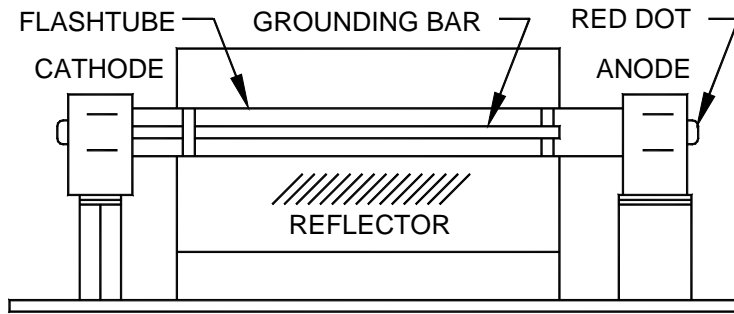

Figure 4 - Flashtube Orientation



WARNING!

Make sure to orient the flashtube and grounding bar as shown on the left. Improper installation may result in diminished light output and damage to the flashtube!

8. Rotate the grounding bar on the flashtube so that it is oriented away from the reflector and toward the window.
9. Slide PC-5000 Printed Circuit module back into the upper slot in the chassis and install the two screws removed in step 3.
10. Reconnect the input power and signal level cable to the J1 connector on the rear panel and restore power to the Strobe.

5.3. REPACKING AND STORAGE

If the 5000 is to be stored for a prolonged period, shipped to another location, or returned to the factory for repair, it should be repacked in the original packaging material. If this has been discarded, the unit should be packaged in a suitable container with sufficient protective material to ensure that the unit cannot move within the carton and is protected from damage that could occur from improper handling.

Any storage area used for the unit should be dry, at a temperature of -40°F to +194°F (-40°C to +90°C).

6.0 DECLARATION OF CONFORMITY

MANUFACTURER:
Excelitas Technologies
35 Congress Street
Salem, Massachusetts 01970 U.S.A.

EUROPEAN REPRESENTATIVE
Excelitas Technologies GmbH:
Wenzel-Jaksch-Str. 31
D-65199 Wiesbaden Germany

Part Number	Model Number	Product Description
302-5000-CE	MVS 5000-CE	Machine Vision Strobe (30Hz, 8uF, 600V)
302-5004	MVS 5004	Machine Vision Strobe (60Hz, 4uF, 600V)
302-5002	MVS 5002	Machine Vision Strobe (15Hz, 16uF, 600V)
302-5008	MVS 5000-UV	Machine Vision Strobe, UV (30Hz, 8uF, 600V)
302-5010	MVS 5010-UV	Machine Vision Strobe, UV (15Hz, 16uF, 600V)

We, Excelitas Technologies, at 35 Congress Street, Salem, Massachusetts, U.S.A., declare that the products described above are in conformity with **EU Low Voltage Directive 73/23/EEC** using the relevant sections of the following standards and other normative documents:

EN61010-1: 2001

Safety requirements for electrical equipment for measurement, controls and laboratory use.

This product has been manufactured in compliance with Excelitas Technologies
I.S. EN ISO 9001: 2008, Quality System, Registration Number 19.1679.



Stewart Tuttle, Quality Assurance