

iFLEX-Agile™ Series CW Optical Parametric Oscillator

Our updated iFLEX-Agile is a high-power, continuous-wave OPO featuring exceptionally broad wavelength tunability.

Ideal for a variety of applications in mass spectrometry, material testing, spectroscopy, and metrology, this new compact instrument allows fine-tuning of specific wavelengths from NIR to MIR, for high-quality output beams of high intensity. Fully controlled via USB computer interface, iFLEX-Agile enables rapid and reproducible settings of any desired wavelength from 1.48 up to 1.95 μm and 2.4 up to 3.8 μm with output powers >1W in its basic configuration, and without any need to change optics or modules. iFLEX-Agile emission linewidths can vary from 200 GHz to below 1 MHz depending on the configuration.

The modular concept allows modification of wavelength tuning range, emission linewidths and output power levels to cost-efficiently meet the custom requirements for specific applications including trace-gas analysis, material inspection, chemical reactions and IR-detector calibration. The iFLEX-Agile can also be customized for extended wavelength range (e.g. additional 740-950nm), narrow linewidth at 2400-4000nm, higher power levels, and extended mode-hop free tuning ranges.

Features

- Broad-wavelength tunability at high-power continuous-wave outputs
- Rapid tunability across 1.48 - 1.95 and 2.4 - 4.0 μm from a single OPO module without any optics change-out
- Output powers >1W
- Configurable with a variety of pump sources to yield a range of output powers and linewidths
- Full software control via USB interface

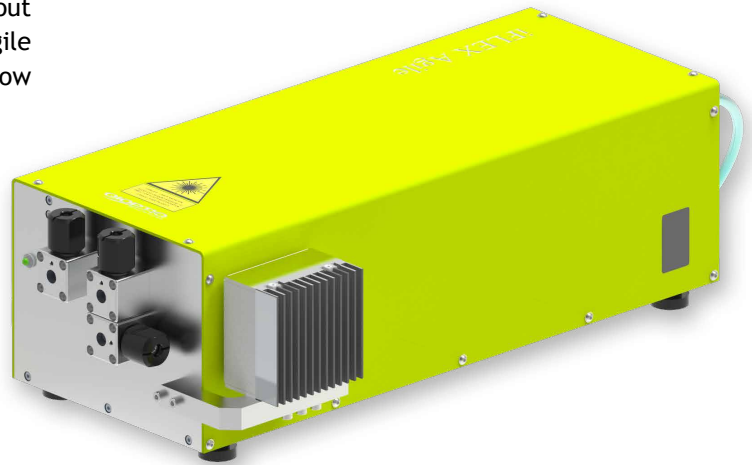

iFLEX-Agile Series cw-OPO

Technical Specifications

iFLEX-Agile series	High power Broad linewidth	High power Narrow linewidth	Extended wavelengths Broad linewidth	Extended wavelengths Narrow linewidth	Low power Broad linewidth	Low power Narrow linewidth
Part Number	8451-900-100-11	8451-900-100-12	8451-900-103-11	8451-900-103-12	8451-900-110-11	8451-900-110-12
Output Beam 1	>1 W at 2.4 - 3.7 μm ¹⁾ >0.2 W at 3.8 - 4.0 μm		>0.5 W at 2.4 - 3.7 μm ¹⁾ >0.1 W at 3.8 - 4.0 μm >0.02 W at 3.8 - 4.5 μm (emission up to 5 μm not guaranteed)		>0.4 W at 2.4 - 3.7 μm ¹⁾ (typ. 0.5 - 0.9 W)	
Output Beam 2	>1 W at 1.5 - 1.95 μm >0.3 W at 1.45 - 1.5 μm		>0.1 W at 1.5 - 1.95 μm >0.03 W at 1.4 - 1.5 μm		>0.1 W at 1.5 - 1.95 μm	
Wavelength tuning	The entire wavelength tuning works via USB					
Polarization	Linear					
Linewidth (1 ms)	< 200 GHz (for Output Beam 1)	<1 MHz	< 200 GHz (for Output Beam 1)	<1 MHz	< 200 GHz (for Output Beam 1)	<1 MHz
Intensity noise, RMS	< 5%					
Cooling method	Air					
Power requirements	220-230 V, approximately 500 W (100-120 V on request)					
Dimensions Pump source	19" Rack mount 3U Module	19" Rack mount 3U Module + Seeder	19" Rack mount 3U Module	19" Rack mount 3U Module + Seeder	19" Rack mount 3U Module	19" Rack mount 3U Module + Seeder
Dimensions Table-top OPO module (LxWxH)	approx. 48 x 24 x 15 cm ³					
Connection for Pump Laser to OPO	Optical fiber (approx. 2m long) is used to connect the Pump Laser to the Table-Top OPO Module					
Control interface	USB interface and control software are included					

¹⁾ Excluded: OH-absorption around 2.8 μm

Typical Power vs. Wavelength

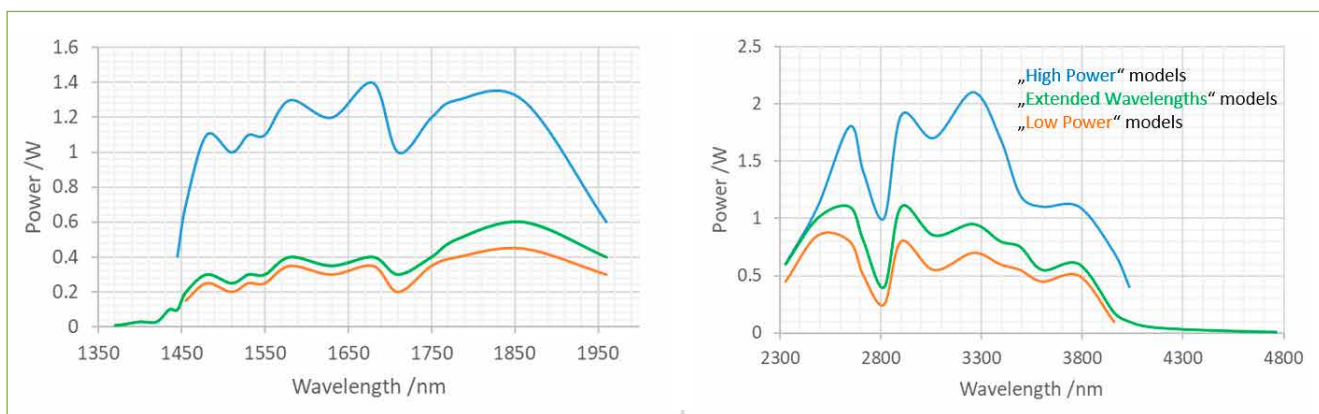

Custom Performance Available

- Extended wavelength range (e.g. 740-950nm)
- Higher power levels
- Mode-hop-free tuning over ranges of >10GHz up to >100GHz (depending on the wavelength)

Dimensions of the Table-Top Module

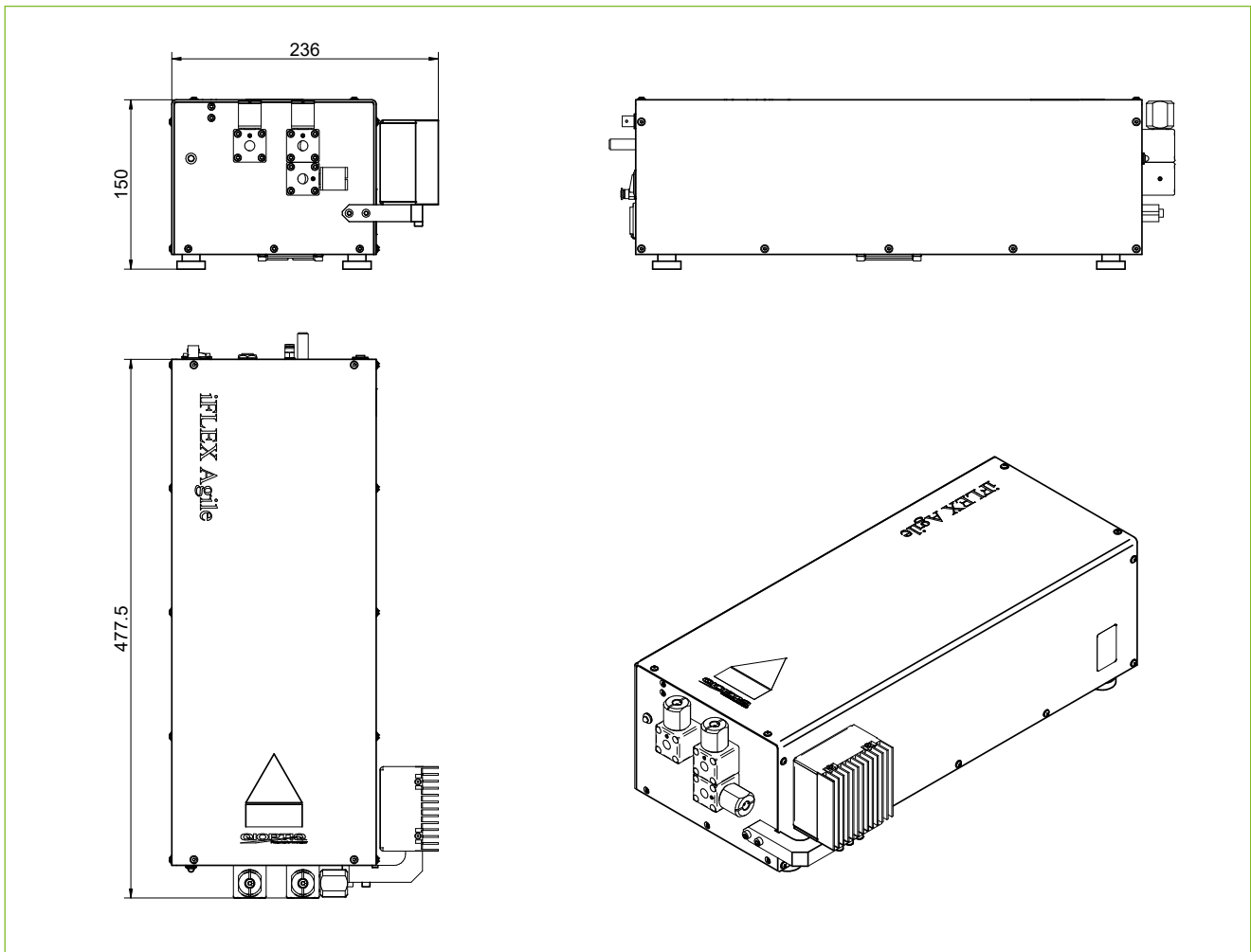

Contact us today

laser@excelitas.com

Europe +49 (0)551 6935-0

North America (+1) 800 429 0257

Asia/Pacific +65 64 99 7777

www.excelitas.com

EXCELITAS
TECHNOLOGIES®

© 2021 Qioptiq Photonics GmbH & Co. KG. All rights reserved. Qioptiq reserves the right to change this document and the technical data contained herein at anytime without notice and disclaims liability for editorial, pictorial and typographical inaccuracies.

O-LF_DS-OPO-EN_2021-05